



Rock Energy Cooperative – Gas Service Manual

Table of Contents

Issued: August 12, 2011

CHAPTER 1 – GENERAL INFORMATION

Purpose	4
Codes and Guidelines	4
Continuity of Service	5
Service Pressures	5
Delivery Pressures	6
Unusual or Large Volume Gas Requirements	7
Addition to Existing Loads	8
Service Connections	8
Member Attachments/Corrosion Protection	8
Relocation of Services – No Change in Load	9

CHAPTER 2 – PROTECTING GAS SYSTEM FROM BACKPRESSURE OR VACUUM

Backpressure Protection	10
Low Pressure or Vacuum Protection	10

CHAPTER 3 – REC FACILITIES ON MEMBER PREMISES

General	11
Access to REC Facilities	11
Tampering with Meters	11

CHAPTER 4 – EXTENSIONS

Responsibility for Extensions	12
-------------------------------------	----

CHAPTER 5 – SERVICE INSTALLATIONS

REC Installation	13
Terms and Conditions	14
Temporary Services for Construction Sites	15
Large Multiple-Occupancy Buildings	15



CHAPTER 6 – METERING INSTALLATIONS AND MEMBER PIPING

REC Metering Facilities/Location.....	16
Member Gas Piping and Equipment.....	17
Gas Meter Connection.....	20
0 to 250 scfh at 7” wc or 2 psig delivery pressure	
Gas Meter Connection.....	22
251 to 630 scfh at 7” wc or	
251 to 1,350 scfh at 2 psig delivery pressure	
Gas Meter Connection.....	24
631 to 1,800 scfh at 7” wc	
Gas Meter Connection.....	26
1,801 to 5,000 scfh at 7” wc or	
2,386 to 5,000 scfh at 2 psig delivery pressure	
Gas Meter Connection.....	28
1,351 to 2,385 scfh at 2 psig delivery pressure or	
0 to 2,700 scfh at 5 psig delivery pressure or	
0 to 3,400 scfh at 10 psig delivery pressure or	
0 to 3,700 scfh 15 psig delivery pressure	
Gas Meter Connection.....	30
2,701 to 9,300 scfh at 5 psig delivery pressure or	
3,401 to 11,600 scfh at 10 psig delivery pressure or	
3,701 to 14,000 scfh at 15 psig delivery pressure	
Gas Meter Connection.....	32
9,301 to 14,600 scfh at 5 psig delivery pressure or	
11,601 to 18,200 scfh at 10 psig delivery pressure or	
14,001 to 22,200 scfh at 15 psig delivery pressure	
Gas Meter Connection.....	34
14,601 to 19,000 scfh at 5 psig delivery pressure	
Multiple Gas Meter Connection.....	36
For two meters	
0 to 250 scfh at 7” wc or	
2 psig delivery pressure	
Gas Meter Set Clearances.....	38

CHAPTER 7 – MANUFACTURED HOMES

Scope.....	41
General.....	41
Manufactured Home Parks.....	42
Gas Service to a Single Manufactured Home.....	43



APPENDIX

Member Piping Material Specifications	47
Energy Conversion Factor Chart	49
Sample: Gas Piping Statement Form.....	50
Sample: Residential Electric and Natural Gas Service Application and Agreement	51



Rock Energy Cooperative – Gas Service Manual

Chapter 1 – General Information

Issued: August 12, 2011

PURPOSE

- A. The purpose of this manual is to supply essential information and requirements to members, employees, architects, engineers, contractors, and others concerned with gas installations in the Rock Energy Cooperative (REC) service area. It is the mission of the cooperative to provide reliable and safe energy services to our members.
- B. Information in this manual is intended to cover typical installations. REC should be consulted regarding special cases and conditions.
- C. Members, architects, contractors, etc. should consult REC during the planning stage about gas service availability and REC's applicable rates and requirements not included in this manual.

ADDITIONAL INFORMATION: This manual will be revised periodically to include industry improvements or other necessary changes. Gas Service Manuals are available either by calling REC or visiting the website at www.rock.coop.

CODES AND GUIDELINES

- A. All member piping installations, including gas utilization equipment, must conform to the National Fuel Gas Code (NFPA 54/ANSI Z223.1-2009) and NFPA 501A for manufactured homes. These are available from the National Fire Protection Association (NFPA) by calling toll-free at 1-800-344-3555 or visiting the website at <http://catalog.nfpa.org>. Installations must also comply with applicable state codes, Title 49 Code of Federal Regulations Part 192, and any local codes or ordinances.
- B. All member installations must comply with REC's Gas Service Manual, regulations, and standards that are on file with the Illinois Commerce Commission (ICC). Any exceptions must receive prior approval from REC.

The information in this manual is based on the following:

- National Fuel Gas Code (NFPA 54/ANSI Z223.1-2009, www.nfpa.org).
- NFPA 501A Standard for Fire Safety Criteria for Manufactured Home Installations, Sites, and Communities.
- Pipeline Safety Regulations 49 CFR Part 192.
- Regulations of the Illinois Commerce Commission.
- REC's documents can be found on its website: www.rock.coop.

If you hear, see, or smell natural gas, call Rock Energy Cooperative at 1-866-752-4550.



- Local governing authorities may impose more stringent requirements than shown in this manual. All installations shall meet these requirements for design, construction, materials, and maintenance of natural gas fuel piping systems, equipment, and related accessories.
- REC must receive a gas Disclosure Statement (available by calling 1-866-752-4550) signed by the member or contractor stating that the member's installation is in compliance with applicable gas codes. This includes pressure testing the gas piping system in accordance with NFPA 54, Section 8.1, NFPA 501A, Section 2.4 and this manual, prior to the meter being installed, connected, and pressurized.
- Each above-ground portion of a gas piping system, other than corrugated stainless steel tubing (CSST), that is upstream from the equipment shut-off valve and is likely to become energized shall be electrically continuous and bonded to an effective ground-fault current path in accordance with NFPA 54, Section 7.13. Gas piping, other than CSST, shall be considered to be bonded when it is connected to appliances that are connected to the appliance grounding conductor of the circuit supplying that appliance. Gas piping or any part of the meter set shall not be used as a grounding electrode.
- CSST gas piping systems shall be bonded to the electrical service grounding system at the point where the gas service enters the building and the bonding jumper shall not be smaller than 6 American Wire Gauge (AWG) copper wire or equivalent, as defined in NFPA 54, Section 7.13.

C. REC may refuse or disconnect service to any installation that does not comply with this manual or may be dangerous to life or property.

CONTINUITY OF SERVICE

REC's goal is to provide continuous gas service and maintain its facilities with minimum inconvenience to members. REC does not guarantee to supply continuous service to its members or maintain constant delivery pressure at all times.

If an interruption of service is unavoidable, REC will make every effort to restore service promptly.

SERVICE PRESSURES

- A. The maximum service pressure available to the member will be limited to the pressure available in the system main at the point of service.
- B. REC provides each building or structure with only one service pressure supplied by one service pipe. Also see Chapter 5, Service Installations.



DELIVERY PRESSURES

- A. Delivery pressure is the pressure provided to the member.
- B. Delivery pressure(s) provided by REC to a member are listed below. Not every delivery pressure is available at every location.

1) Standard Delivery Pressure

REC's standard delivery pressure for natural gas service is a nominal 7 inches water column (7" wc). This pressure is available for total connected gas loads up to 5,000 standard cubic feet per hour (scfh). Members with a total connected gas load of greater than 5,000 scfh will be served at a higher delivery pressure. (See "Large Volume and/or High Pressure Service" below.)

For a 7" wc delivery pressure to a member, the member's piping system must be able to receive, withstand, and control 2 pounds per square inch gauge (psig) of gas pressure. The pressure at the outlet of REC's last point of service could fluctuate from 5" wc to 9" wc with a standard 7" wc delivery pressure.

2) Large Volume and/or High Pressure Service

- a) On REC's distribution system, the member may receive one of the following delivery pressures:

- (1) 2 psig (1.8 psig minimum at point of delivery (meter location))
- (2) 5 psig (4.5 psig minimum at point of delivery (meter location))
- (3) 10 psig (8 psig minimum at point of delivery (meter location))
- (4) 15 psig (12 psig minimum at point of delivery (meter location))

Member requirements for these pressures may require special design considerations. See REC for these requirements.

- b) REC may approve delivery pressure higher than standard pressure when the following conditions exist:

- (1) REC has the ability to supply the requested delivery pressure and volume.
- (2) The member's gas piping system is constructed to safely receive, withstand, and control gas (i.e. pressure regulation) from REC as follows:

- (a) For 2 psig delivery pressure to a member, the member's piping system must be able to receive, withstand, and control 5 psig of



gas pressure. Maximum connected load available for 2 psig service is 5,500 scfh.

- (b) For 5 psig delivery pressure to a member, the member's piping system must be able to receive, withstand, and control 15 psig of gas pressure.*
- (c) For 10 psig delivery pressure to a member, the member's piping system must be able to receive, withstand, and control 20 psig of gas pressure.*
- (d) For 15 psig delivery pressure to a member, the member's piping system must be able to receive, withstand, and control 25 psig of gas pressure.*
- (e) For 60 psig delivery pressure to a member, the member's piping system must be able to receive, withstand, and control 70 psig of gas pressure.

* See REC for suggested methods of meeting this requirement.

* NOTE: Member's requirements for these pressures may require special design considerations. See REC for these requirements.

(3) Any exception to the above must be specifically approved by REC.

- 3) REC will only provide one delivery pressure per member. The member must provide their own regulation and over-pressure protection to meet any additional delivery pressure requirements.
- 4) Delivery pressures are measured at the outlet of REC's last point of service, typically the outlet of the meter.

UNUSUAL OR LARGE VOLUME GAS REQUIREMENTS

Unusual or large volume gas installations may require extensive alterations to REC's gas system which take a considerable amount of time to complete. Such projects should be discussed with REC well in advance of the member's start-up date in order to provide ample time for contract arrangements and construction of REC facilities.



ADDITION TO EXISTING LOADS

To enable REC to change its equipment and prevent service problems, the member shall give advance notice of permanent or temporary load changes or changes in pressure requirements. Load increases may require a change of regulator, service, and meter or delivery pressure.

Members failing to notify REC of load increases are subject to charges for damaged equipment. REC must receive a gas Disclosure Statement that is signed by the member or contractor stating that the gas facilities are installed in accordance with all applicable gas codes and requirements. Examples of increased load are: upgrading to tankless water heater, increasing size of furnace, adding grain dryers, installing additional gas equipment, etc.

SERVICE CONNECTIONS

REC will make all service connections to its gas system, including meter installations. Connection to or alteration of REC's gas service or other equipment is prohibited.

MEMBER ATTACHMENTS/CORROSION PROTECTION

In order to maintain adequate corrosion protection for the gas system, the member is not permitted to attach, hang, or support any object from REC's meter installation or piping. As required by all federal, state, and local codes and NFPA 54, any member gas piping that is subject to corrosion must be protected by the user. All above-ground steel pipe must be painted to protect against atmospheric corrosion (NFPA 54, Section 5.6.6).

All piping passing through an outside wall shall also be protected against corrosion by coating or wrapping with an inert material approved for such applications (NFPA 54, Section 7.2.1).

Underground piping, where installed below grade through the foundation or basement wall of the building, shall be encased in a protective sleeve. The annular space between the gas piping and the sleeve shall be sealed at the wall to prevent the entry of gas, water, insects, or rodents (NFPA 54, Section 7.1.5). Contact REC during planning stage for preapproval of underground piping.

All underground metallic piping must be coated and cathodically protected (NFPA 54, Section 7.1.3). REC's gas piping system must also be electrically isolated from all member piping, wiring, or grounding systems.

Each above-ground portion of a gas piping system, other than CSST, that is upstream from the equipment shutoff valve and is likely to become energized shall be electrically continuous and bonded to an effective ground-fault current path in accordance with NFPA 54, Section 7.13. Gas piping, other than CSST, shall be considered to be bonded when it is connected to appliances that are connected to the appliance grounding conductor of the circuit supplying



that appliance. Gas piping or any part of the meter set shall not be used as a grounding electrode.

CSST gas piping systems shall be bonded to the electrical service grounding system at the point where the gas service enters the building and the bonding jumper shall not be smaller than 6 AWG copper wire or equivalent, as defined in the NFPA 54, Section 7.13.

RELOCATION OF SERVICES – NO CHANGE IN LOAD

Where the member requests a change or relocation of REC's installed gas service facilities or where such a change, in the judgment of REC, is required due to construction, reconstruction, alteration, or demolition on the member's premises, the cost of the change in gas service facilities will be paid by the member per the appropriate gas tariff. Refer to Chapter 5, Service Installations, for additional details and requirements for service installation.



Rock Energy Cooperative – Gas Service Manual

Chapter 2 – Protecting Gas System from Backpressure or Vacuum

Issued: August 12, 2011

BACKPRESSURE PROTECTION

- A. Backpressure protection must be installed when gas utilization equipment is connected in such a way that air, oxygen, standby gases, or fuels could be forced into REC's gas supply system. Suitable protective devices shall be installed as close to the utilization equipment as practicable. Gas and air combustion mixers incorporating double diaphragm "zero" or "atmosphere" governors or regulators require no further protection unless connected directly to compressed air or oxygen at pressures of 5 psig or more (NFPA 54, Section 5.7.4).
 - B. In order to prevent flow back into REC's meter when liquefied petroleum gas or other supplementary gas is used as a standby fuel source by the member, a three-way valve may be substituted for a check valve, if desired, in order to admit the standby gas supply while shutting off the natural gas supply (NFPA 54, Section 5.3.2).
 - C. Natural gas compressors shall be connected to REC's system through a check valve capable of withstanding the outlet pressure of the compressor.
-

LOW PRESSURE OR VACUUM PROTECTION

A suitable protective device shall be installed between the meter and the gas utilization equipment if the operation of the equipment is such that it may produce a vacuum or a dangerous reduction in gas pressure at the meter (i.e. gas compressors). Such devices include, but are not limited to, mechanical, diaphragm-operated, or electrically operated low-pressure shutoff valves.



Rock Energy Cooperative – Gas Service Manual

Chapter 3 – REC Facilities on Member Premises

Issued: August 12, 2011

GENERAL

REC shall have the right to install and maintain its facilities on a member's premises as required in order to supply adequate service. All such facilities shall remain REC property.

ACCESS TO REC FACILITIES

REC shall have the right of access to its facilities located on member premises for inspection, maintenance, testing, and restoration of service. REC will attempt to provide advance notice to the member of the need for access whenever possible. Access includes requiring a clear path to the meter free from trees, bushes, plants, yard sheds, buildings, etc. REC shall have the right to cut back trees, bushes, plants, etc., if a clear path is not provided and maintained.

No structure shall be placed over gas service or main pipe. Structures found to be built over any portion of a gas service or main will be moved or the gas service pipe rerouted at member's expense.

TAMPERING WITH METERS

- A. Meters and meter equipment are sealed by REC. Breaking of seals by unauthorized persons is prohibited.
- B. Meters shall not be removed or relocated except by authorized REC employees. Tampering with meters, regulators, valves, or any REC property is prohibited, and violators may be prosecuted to the full extent of the law. Violators will be held responsible for metering errors, equipment damage, and unmetered gas.



Rock Energy Cooperative – Gas Service Manual

Chapter 4 – Extensions

Issued: August 12, 2011

RESPONSIBILITY FOR EXTENSIONS

- A. REC constructs, owns, and maintains all extensions of its gas distribution system and makes all service connections.
- B. REC installs, owns, and maintains the gas service lateral to the meter set assembly on the member's premises in accordance with REC's applicable rates and extension rules.
- C. REC will install gas main or gas services only on routes suitable for gas piping and facilities.
- D. Underground gas piping and facilities shall meet a minimum separation of 12 inches from other structures or facilities.
- E. Contact REC for fee schedule and extension cost.



Rock Energy Cooperative – Gas Service Manual

Chapter 5 – Service Installations

Issued: August 12, 2011

REC INSTALLATION

- A. After consulting with the member, REC specifies the location of the service metering point.
- B. REC provides each building or structure with only one service pressure (see Chapter 1, Service Pressures) supplied by one service pipe to a metering installation(s) located adjacent to or in a building or structure located on the member's premises. The above rule will be strictly adhered to except as follows:

Exception No. 1 – For a row house, condominium, or townhouse that is a place of abode not more than three stories in height, arranged to accommodate three or more attached row living units in which each living unit is separated from the adjoining unit by a firewall(s)* as allowed by the local Authority Having Jurisdiction (AHJ), a separate service pipe may be provided for each two attached units.

Exception No. 2 – For duplexes where the dwelling units do not share a common wall, a separate service pipe may be provided for each unit (i.e. separated by garage).

Exception No. 3 – For duplexes or condominiums with zero lot lines, in which each property unit is separated from the adjoining property unit by a firewall(s)* as allowed by the local AHJ, a separate service pipe may be provided for each property unit.

Note: If the developer elects to pipe across property units from one central delivery point (i.e. one service serves the entire structure), the developer is responsible for securing all required easements from the adjacent property owners prior to gas service being installed. All required easements are to be granted to REC.

* All firewalls must extend from the basement or lowest floor to the under-side of the roof deck and have no HVAC vents or other piping between the units through the firewall and may have no metallic paths bonding the units together, in accordance with the International Building Code (IBC) Chapter 7, 2009 ed. Listed below is a guide to typical firewall ratings:

- 1-Hour – Two ¼-inch sheets of sheet rock separated by a 2x4 stud.
- 2-Hour – Two ¾-inch sheets of sheet rock separated by a 2x4 stud.



3-Hour – Four $\frac{5}{8}$ -inch sheets of sheet rock separated by 2 sets of 2x4 studs creating double walls.

4-Hour or greater – 8-inch cinder blocks walls.

NOTE: The AHJ has the final say on what firewall construction is required.

All other exceptions must be specifically approved by REC. Extension of service to each delivery point will be installed in accordance with the applicable REC extension rules (see Chapter 4). Each delivery point will be individually metered.

- C. Service will not be extended to buildings or structures for gas usage that is determined to be a non-essential use of natural gas or does not meet energy conservation standards per federal, state, or local codes and ordinances.
- D. For all meter installations of 1,800 scfh or less at 7" wc delivery pressure and for all meter connections of 1,350 scfh or less at 2 psig delivery pressure, REC will install a gas shutoff valve immediately after its facility, which will become the property of the member. The member is responsible for all operation and maintenance of this valve after initial installation. This valve is to be used by the member or their agent for all non-emergency gas shutoff. It can also be used in emergencies when REC's gas meter stop is inaccessible.
- E. For all meter installations greater than 1,800 scfh at 7" wc delivery pressure and for all meter connections greater than 1,350 scfh at 2 psig or greater delivery pressure, REC shall install a gas shutoff valve immediately before the member-owned piping, which will remain the property of REC. This valve is for use only by REC, unless special arrangements are made to allow members to operate the valve.

TERMS AND CONDITIONS

REC must receive a gas Disclosure Statement that is signed by the member or contractor stating that the installation is in compliance with applicable gas codes. This includes pressure testing the gas piping system in accordance with NFPA 54, Section 8.1 and REC's Gas Service Manual before the system is connected and pressurized.

- A. REC may refuse or disconnect service to any installation that does not comply with this manual or may be dangerous to life or property.
- B. The member shall make application to REC for the proposed gas service and obtain approval for the meter location before starting installation of the member gas piping. Any construction contributions must be paid to REC prior to service installation scheduling.
- C. The service pipe will be installed only after final grade levels have been established and other conditions are found to be satisfactory by REC. Rough grade must be within 6



- inches of final grade. The member shall clear the proposed pipe route of vegetation, construction materials, and other obstacles that prevent the installation of the gas service and advise REC of known underground obstacles such as septic tanks, invisible fences, sprinkler systems, etc. The member shall provide the right of access at no expense to REC for the installation and maintenance of the gas service pipe. No building, structure, or tree shall be placed over the pipe route.
- D. After installation of the gas service pipe, the grade shall not be increased or decreased more than 6 inches without notifying REC before grading begins. If rebuilding and/or relocation of the gas service and metering equipment are required due to a grade change, the member must pay the entire cost.

TEMPORARY SERVICES FOR CONSTRUCTION SITES

The member shall make application to REC for the proposed temporary service to determine if such service can be provided and to obtain approval of the service location.

LARGE MULTIPLE-OCCUPANCY BUILDINGS

The member shall consult with REC when planning a building that may include an REC-owned distribution system in or on the building.



Rock Energy Cooperative – Gas Service Manual

Chapter 6 – Metering Installations and Member Piping

Issued: August 12, 2011

REC METERING FACILITIES/LOCATION

- A. REC will install, own, and maintain its own metering and control equipment on the member's premises. Gas metering equipment will normally be installed adjacent to the member's building or facility at a location selected by REC after consulting with the member.
- B. Adequate space shall be provided at the meter location for easy access to the meter, regulator, relief valve, and manifold piping without cost to REC. REC personnel shall have free access to such equipment at all reasonable times (see Meter Installation Specifications on Pages 6-25 of Chapter 6).
- C. Whenever possible, the gas meter, regulator, and relief valve will be located outside (see recommended location drawings on Pages 24 and 25 of Chapter 6).
- D. At no time shall a regulator or relief valve vent line be connected to any other vent line nor shall a regulator control line be connected to any other control line. No changes or alterations shall be made to REC piping, vent lines, or control lines by anyone other than REC personnel (NFPA 54, Section 5.8.5).
- E. Outside meter sets will be located in such a way that any escaping gas will flow freely into the atmosphere and away from any opening in the building (see gas meter set clearance drawings on Pages 24 and 25 of Chapter 6).
- F. If an inside meter set requires dual regulation, the first stage regulator must be located outside and any inside regulator and relief valve must be properly vented outside to the atmosphere. Meters and regulators located inside shall be placed as near as possible to the point of service line entrance.
- G. When selecting a metering location, consideration must be given to protecting the meter set from damage by external forces. Examples of such forces include, but are not limited to, motor vehicles, excessive vibration, falling, accumulation of ice or snow, and pedestrian traffic (NFPA 54, Section 5.7.2).

Any meter set that is installed adjacent to a driveway, roadway, or parking lot must be located and protected in such a manner that the potential for being damaged or covered during snow removal is minimized. REC will provide vehicular protection deemed necessary at the time of initial service installation. The member may be responsible for or charged for any subsequent vehicular protection.



When needed, the member shall provide protection from falling ice, snow, or other objects, including the accumulation of ice or snow. Such protection shall not enclose the meter set nor prohibit access for meter reading or other normal maintenance operations and must be designed to allow any escaping gas to flow freely to the atmosphere away from openings in the building (NFPA 54, Section 7.1.2).

- H. Regulator and relief valve vent openings shall be a minimum of 5 feet from electric transformers (see Page 25 of Chapter 6) and 3 feet from sources of ignition (NFPA 54, Section 5.8.5).

MEMBER GAS PIPING AND EQUIPMENT

- A. Members shall furnish, install, and maintain all building gas piping and gas utilization equipment beyond the meter outlet at member's expense. Such gas piping and equipment shall be installed, securely supported with adequate bracketing, located where it will be protected from physical damage, and maintained at all times in accordance with all applicable codes and regulations and by REC's Gas Service Manual. The member shall protect their gas piping system from corrosion (see Chapter 1, General Information). REC assumes no responsibility for the installation, maintenance, or operation of the member's gas piping and equipment beyond the meter outlet. However, REC reserves the right to discontinue gas service at any time after reasonable notice, when practicable, if such gas piping or equipment is in an unsafe condition in the opinion of REC (NFPA 54, Sections 5.4 and 5.6).
- B. Member gas piping shall be of adequate size for any gas load that may be reasonably expected to develop and shall be pressure tested and gas tight (NFPA 54, Sections 8.1 and 5.5.1). Any meter set changes required due to improper sizing of member piping will be done at the member's expense.
- C. For multiple meter installations, all meters served by one service pipe shall be installed at the same location. Gas piping at multiple meter installations shall be plainly marked by a metal tag or other permanent means attached by the piping installer, designating the building or the part of the building being supplied by each meter (NFPA 54, Section 5.7.5). For multiple meter installation specifications, see Page 24 of Chapter 6.
- D. All members converting from another fuel and wishing to use their existing piping system for natural gas must have their piping system inspected by a plumber or heating contractor. REC must receive a gas Disclosure Statement signed by the inspecting party stating that the member's installation is in compliance with applicable gas codes and REC's Gas Service Manual prior to the meter being installed, connected, and pressurized.



- E. Each above-ground portion of a gas piping system, other than corrugated stainless steel tubing (CSST), that is upstream from the equipment shutoff valve and is likely to become energized shall be electrically continuous and bonded to an effective ground-fault current path in accordance with NFPA 54, Section 7.13. Gas piping, other than CSST, shall be considered to be bonded when it is connected to appliances that are connected to the appliance grounding conductor of the circuit supplying that appliance. Gas piping or any part of the meter set shall not be used as a grounding electrode.
- F. CSST gas piping systems shall be bonded to the electrical grounding system at the point where the gas service enters the building. The bonding jumpers shall not be smaller than 6 AWG copper wire or equivalent (NFPA 54, Section 7.13).
- G. When copper, CSST, or piping material other than steel pipe is used for the member piping, steel pipe shall be used from the meter set to the point of transition. The transition shall be made inside the building using fittings approved by NFPA 54, Section 5.6. In the rare event that building design elements or construction features prevent the transition from occurring inside the building, the transition may be made on the external side of the building as close as possible to the point of entrance to the building and be rigidly supported or securely fastened to the building wall. When CSST is used inside a building, external transitions to REC-owned steel piping must be made with a manufacturer approved flange mount termination plate. If CSST piping is to be connected to member-owned steel piping to serve outdoor equipment, a manufacturer-approved fitting must be used at the point of transition.

The two figures on the following page depict the configuration of an outdoor transition to indoor CSST piping using a flange mounted termination plate.



TOP VIEW

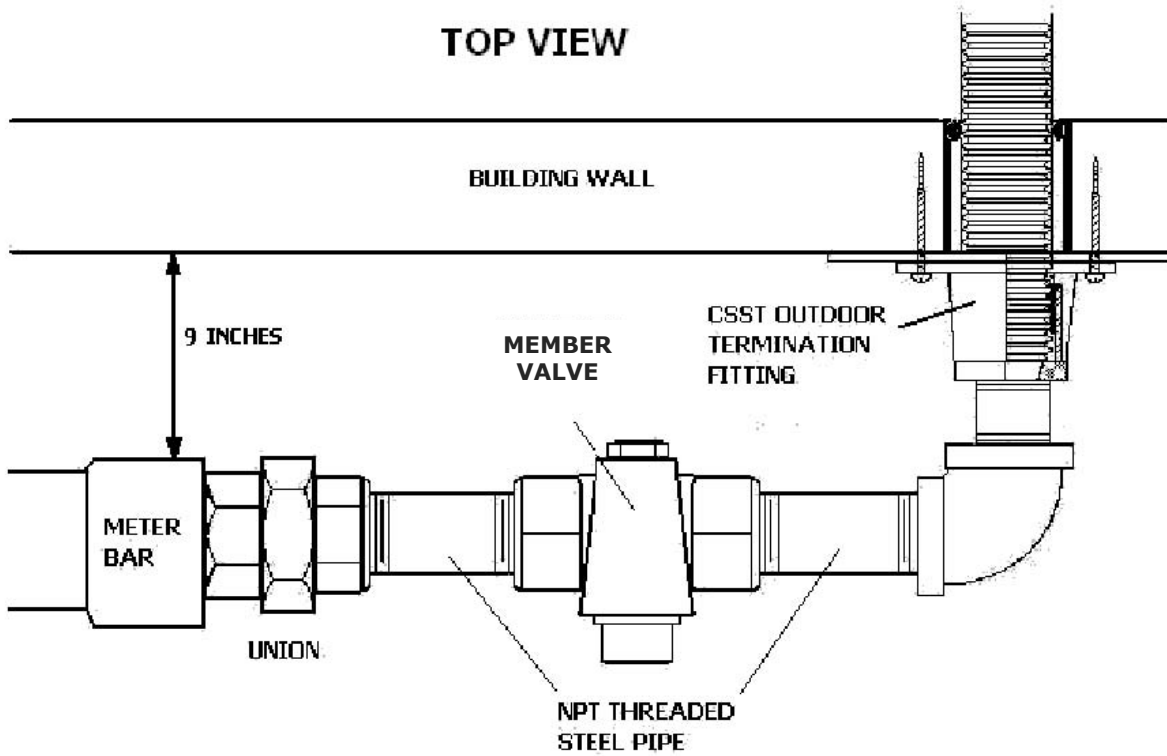

FRONT VIEW

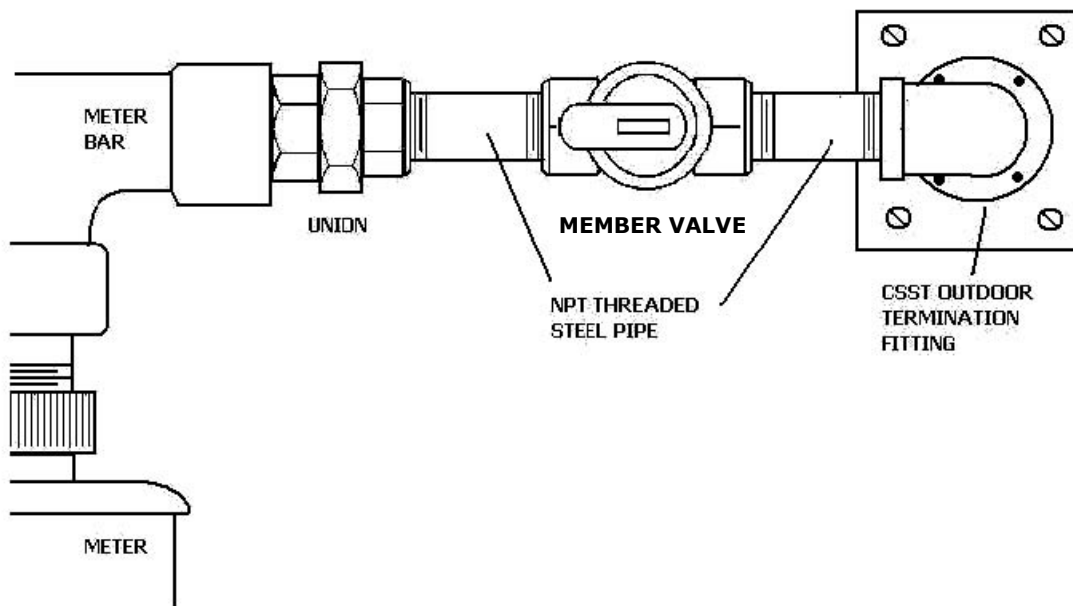



GAS METER CONNECTION

0 to 250 scfh at 7" wc or 2 psig delivery pressure

REC will install, own, and maintain:

- 1) Gas service lateral.
- 2) Gas service shutoff valve.
- 3) Gas regulator.
- 4) Gas meter connection.
- 5) Gas meter.

The member shall own and maintain:

- 6) 1" shutoff valve (provided by the utility).
- 7) All member piping.

(See figure on next page.)

All external member piping must be securely supported and located where it will be protected from physical damage (see Page 3 of Chapter 6 for piping requirements for copper or CSST).



GAS METER CONNECTION (Continued)

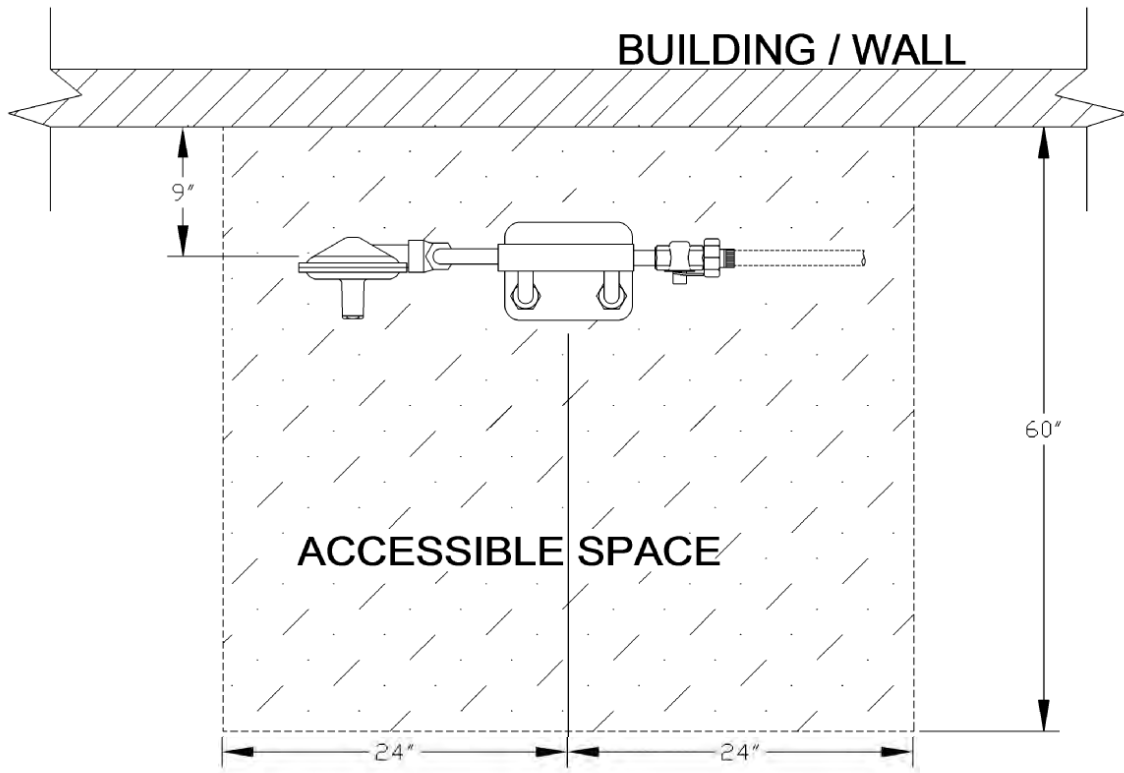

TOP VIEW

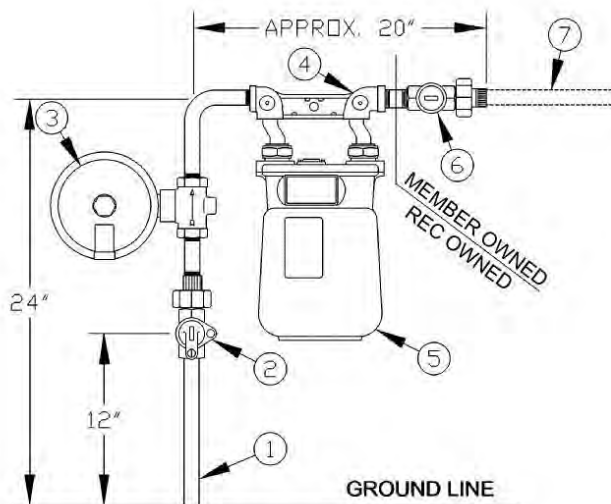

FRONT VIEW

(Dimensions Approximate)



GAS METER CONNECTION

251 to 630 scfh at 7" w.c. delivery pressure or

251 to 1,350 scfh at 2 psig delivery pressure

REC will install, own and maintain:

- 1) Gas service lateral
- 2) Gas service shut off valve
- 3) Gas regulator
- 4) Gas meter connection
- 5) Gas meter

The member shall own and maintain:

- 6) 1-1/4" shut-off valve (provided by the utility)
- 7) All member piping

(See figure on next page)

All external member piping must be securely supported, and located where it will be protected from physical damage (see page 3 of this chapter for piping requirements for copper or CSST).



GAS METER CONNECTION (Continued)

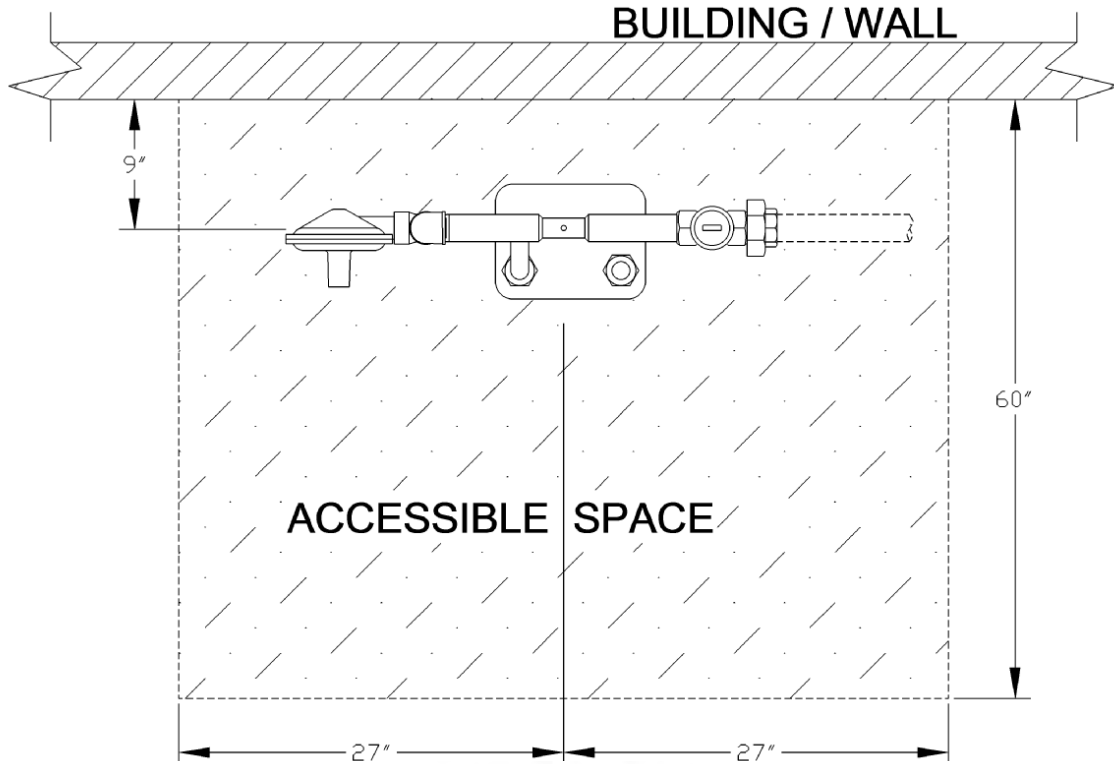

TOP VIEW

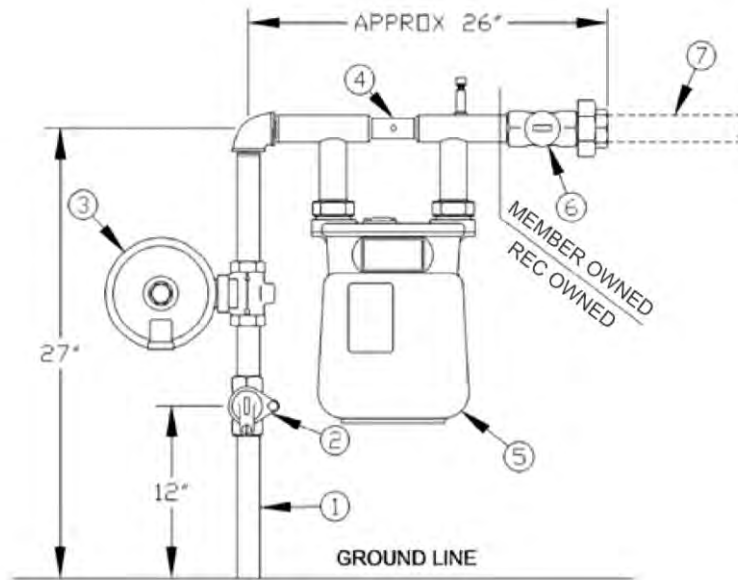

FRONT VIEW

(Dimensions Approximate)



GAS METER CONNECTION

631 to 1,800 scfh at 7" wc delivery pressure

REC will install, own, and maintain:

- 1) Gas service lateral.
- 2) Gas service shutoff valve.
- 3) Gas regulator.
- 4) Gas meter connection.
- 5) Gas meter.
- 6) 1 ¼" shutoff valve (provided by the utility).

The member shall own and maintain:

- 7) All member piping.

(See figure on next page)

All external member piping must be securely supported and located where it will be protected from physical damage (see Page 3 of this chapter for piping requirements for copper or CSST).



GAS METER CONNECTION (Continued)

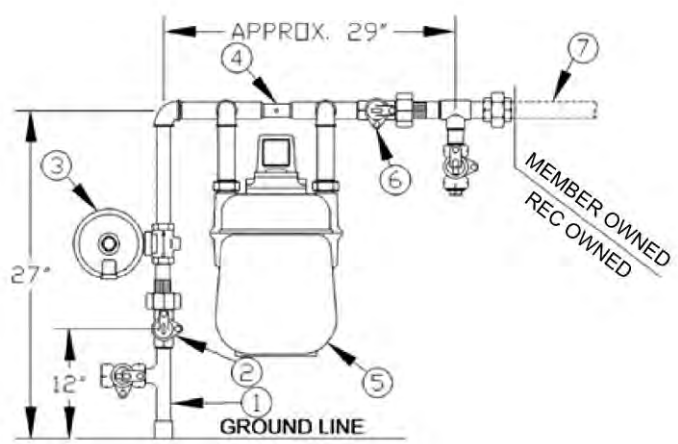
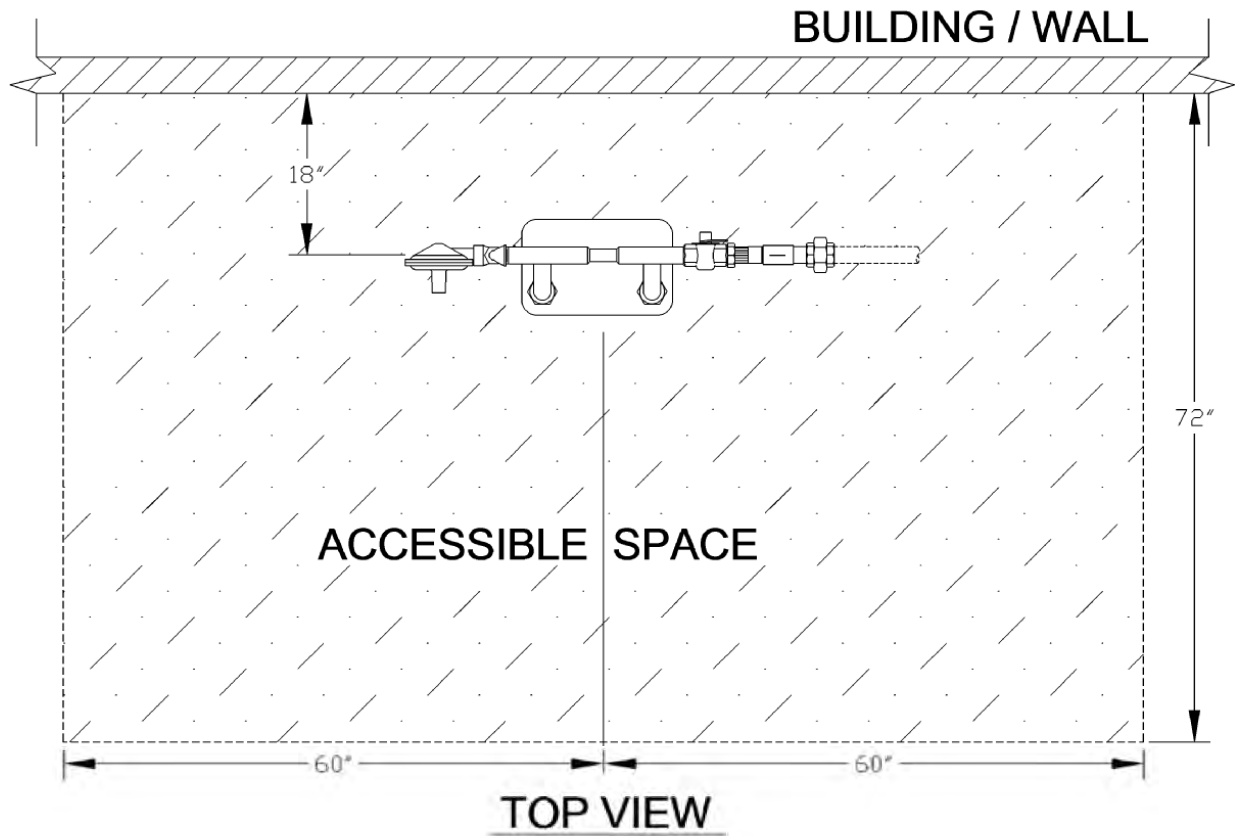

FRONT VIEW

(Dimensions Approximate)



GAS METER CONNECTION

1,801 to 5,000 scfh at 7" wc delivery pressure or

2,386 to 5,000 scfh at 2 psig delivery pressure

REC will install, own, and maintain:

- 1) Gas service lateral.
- 2) Gas service shutoff valve.
- 3) Gas regulator.
- 4) Gas strainer.
- 5) Gas meter connection.
- 6) Gas meter.
- 7) 3" steel nipple (on meter connection outlet).
- 8) Bypass valve.
- 9) Concrete meter pad.
- 10) Relief valve.

The member shall install, own, and maintain:

- 11) All member piping.

(See figure on next page.)

All external member piping must be securely supported and located where it will be protected from physical damage (see page 3 of this chapter for piping requirements for copper or CSST).



GAS METER CONNECTION (Continued)

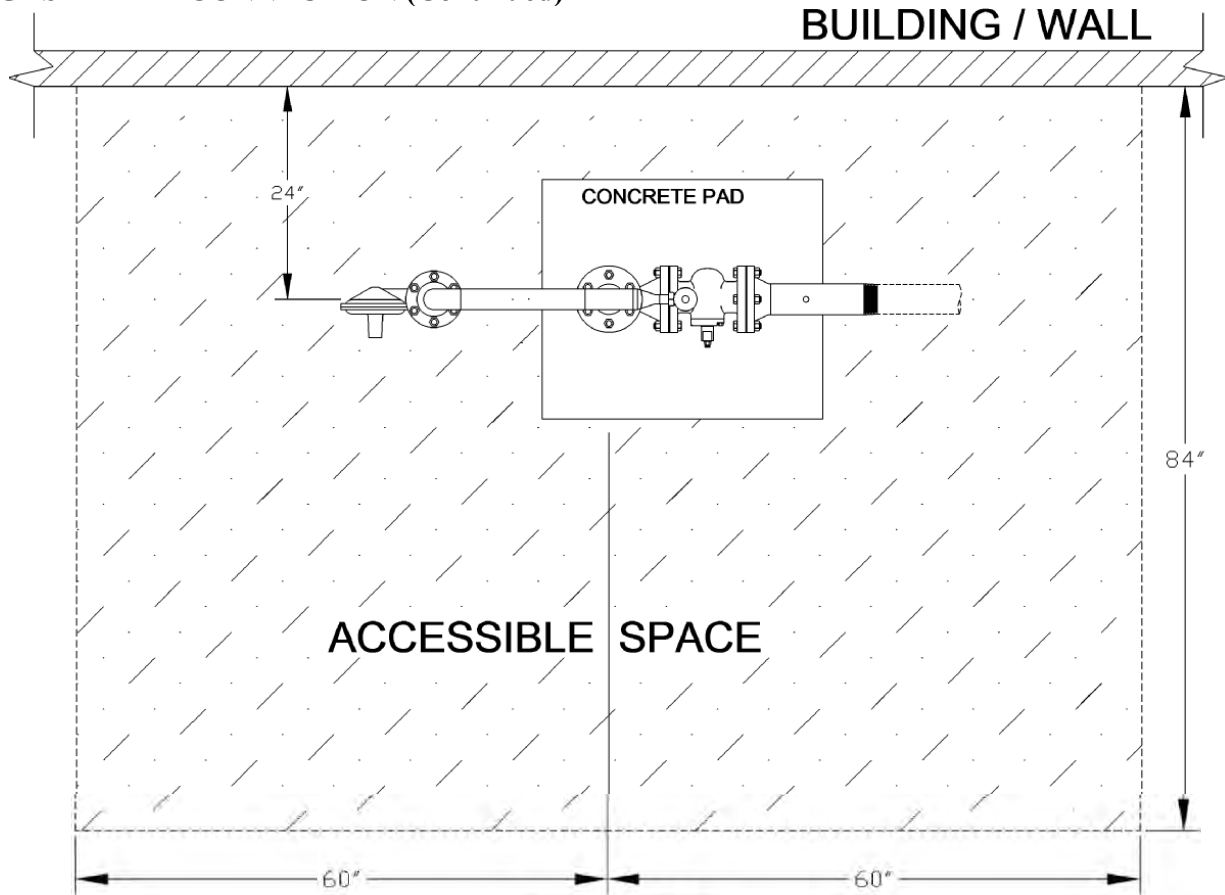

TOP VIEW

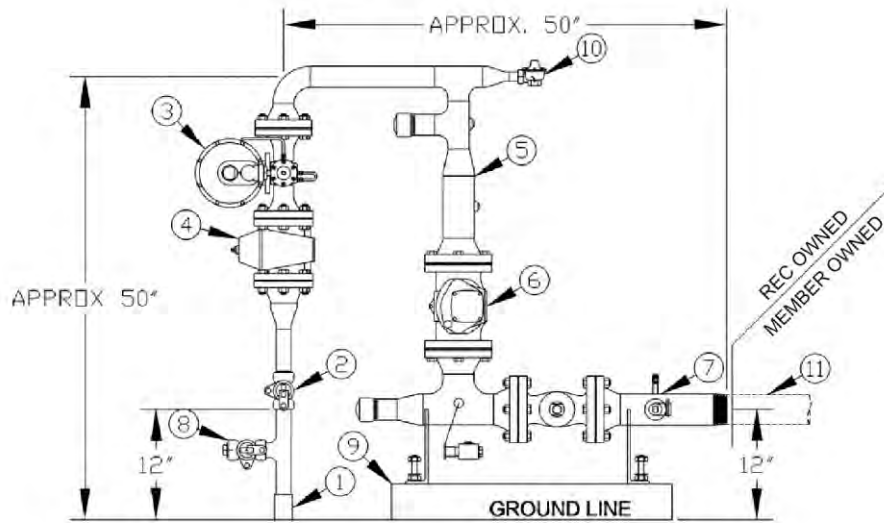

FRONT VIEW

(Dimensions Approximate)



GAS METER CONNECTION

1351 to 2,385 scfh at 2 psig delivery pressure or

0 to 2,700 scfh at 5 psig delivery pressure or

0 to 3,400 scfh at 10* psig delivery pressure or

0 to 3,700 scfh at 15* psig delivery pressure

REC will install, own, and maintain:

- 1) Gas service lateral.
- 2) Gas service shutoff valve.
- 3) Gas regulator.
- 4) Gas meter connection.
- 5) Gas meter.
- 6) Bypass connection.
- 7) Relief valve.
- 8) 1¼" shutoff valve (provided by the utility).

The member shall own and maintain:

- 9) All member piping.

(See figure on next page)

All external member piping must be securely supported and located where it will be protected from physical damage (see page 3 of this chapter for piping requirements for copper or CSST).

For delivery pressures greater than 5 psig, all member piping must be steel pipe.*

***See NFPA 54, Section 5.5.1 for member piping requirements for delivery pressures over 5 psig.**



GAS METER CONNECTION (Continued)

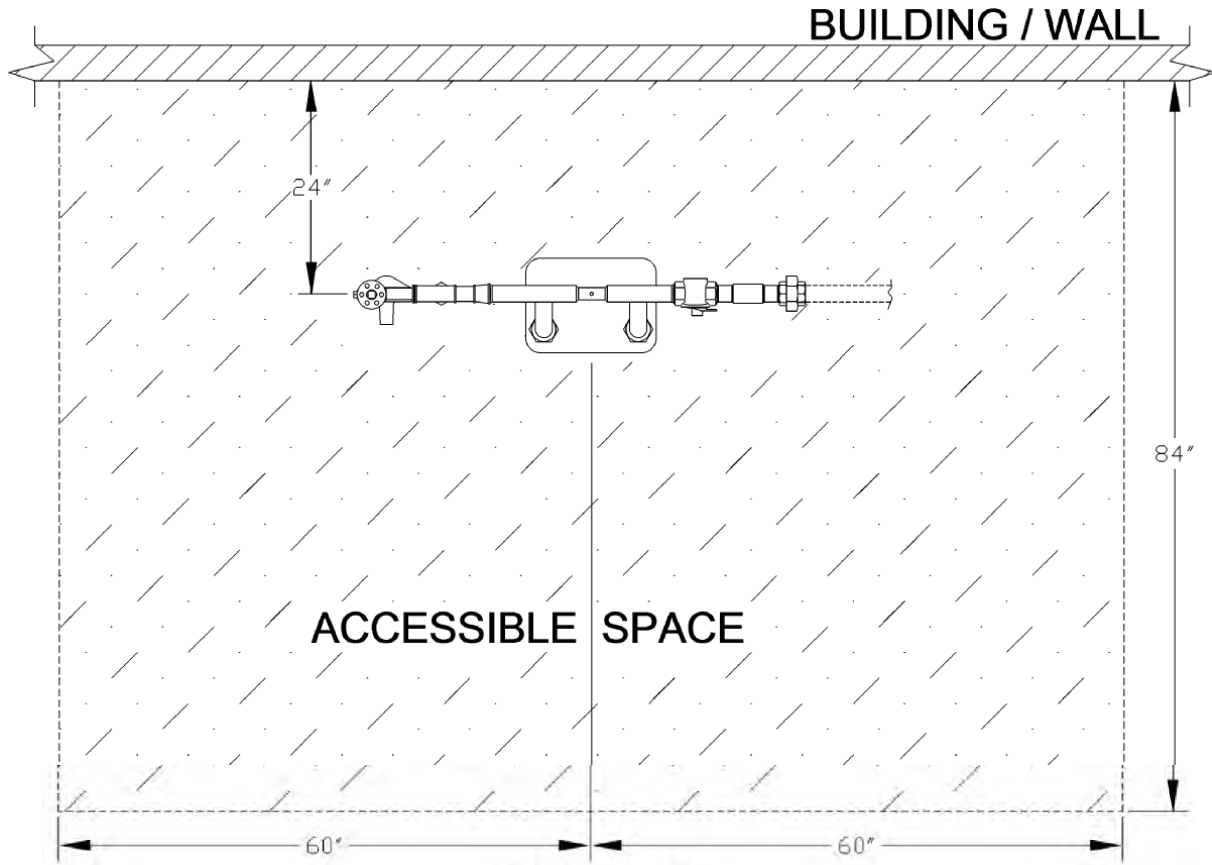

TOP VIEW

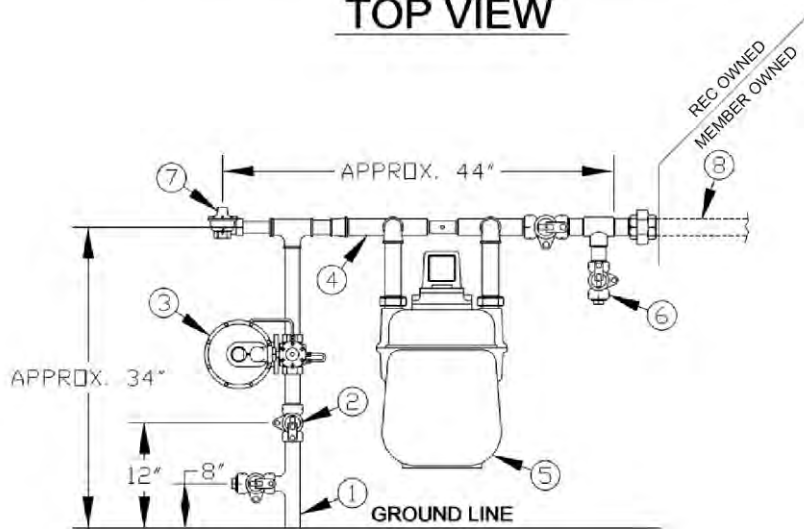

FRONT VIEW

(Dimensions Approximate)



GAS METER CONNECTION

2,701 to 9,300 scfh at 5 psig delivery pressure or

3,401 to 11,600 scfh at 10* psig delivery pressure or

3,701 to 14,000 scfh at 15* psig delivery pressure

REC will install, own, and maintain:

- 1) Gas service lateral.
- 2) Gas service shutoff valve.
- 3) Gas regulator.
- 4) Gas strainer.
- 5) Gas meter connection.
- 6) Gas meter.
- 7) 3" steel nipple (on meter connection outlet).
- 8) Bypass valve.
- 9) Concrete meter pad.
- 10) Relief valve.

The member shall install, own, and maintain:

- 11) All member piping.

(See figure on next page.)

All external member piping must be securely supported and located where it will be protected from physical damage (see page 3 of this chapter for piping requirements for copper or CSST).

For delivery pressures greater than 5 psig, all member piping must be steel pipe.*

***See NFPA 54, Section 5.5.1 for member piping requirements for delivery pressures over 5 psig.**



GAS METER CONNECTION - Continued

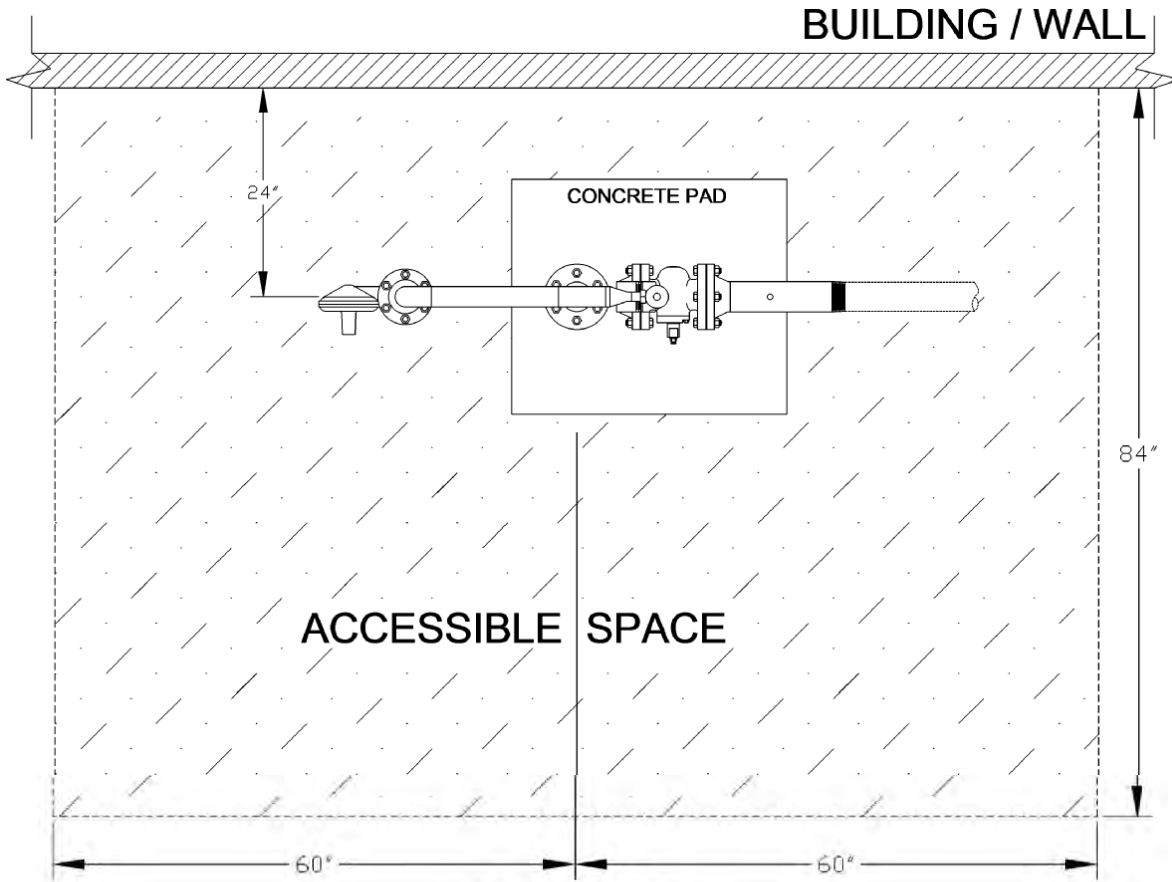

TOP VIEW

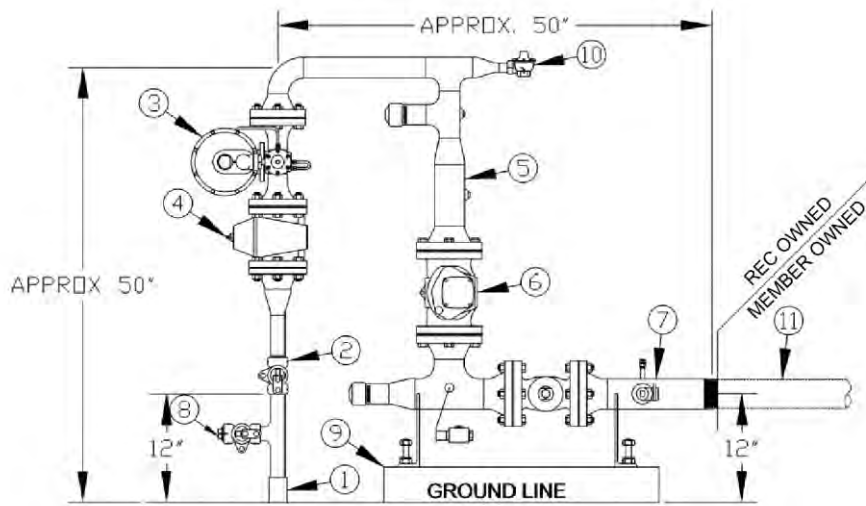

FRONT VIEW

(Dimensions Approximate)



GAS METER CONNECTION

9,301 to 14,600 scfh at 5 psig delivery pressure or

11,601 to 18,200 scfh at 10* psig delivery pressure or

14,001 to 22,200 scfh at 15* psig delivery pressure

REC will install, own, and maintain:

- 1) Gas service lateral.
- 2) Gas service shutoff valve.
- 3) Gas regulator.
- 4) Gas strainer.
- 5) Gas relief valve.
- 6) Gas meter connection.
- 7) Gas meter.
- 8) 4" steel nipple (on meter connection outlet).
- 9) Concrete meter pad.
- 10) Bypass valve.

The member shall install, own, and maintain:

- 11) All member piping.

(See figure on next page.)

All external member piping must securely supported and located where it will be protected from physical damage (see page 3 of this chapter for piping requirements for copper or CSST).

For delivery pressures greater than 5 psig, all member piping must be steel pipe.*

***See NFPA 54, Section 5.5.1 for member piping requirements for delivery pressures over 5 psig.**



GAS METER CONNECTION (Continued)

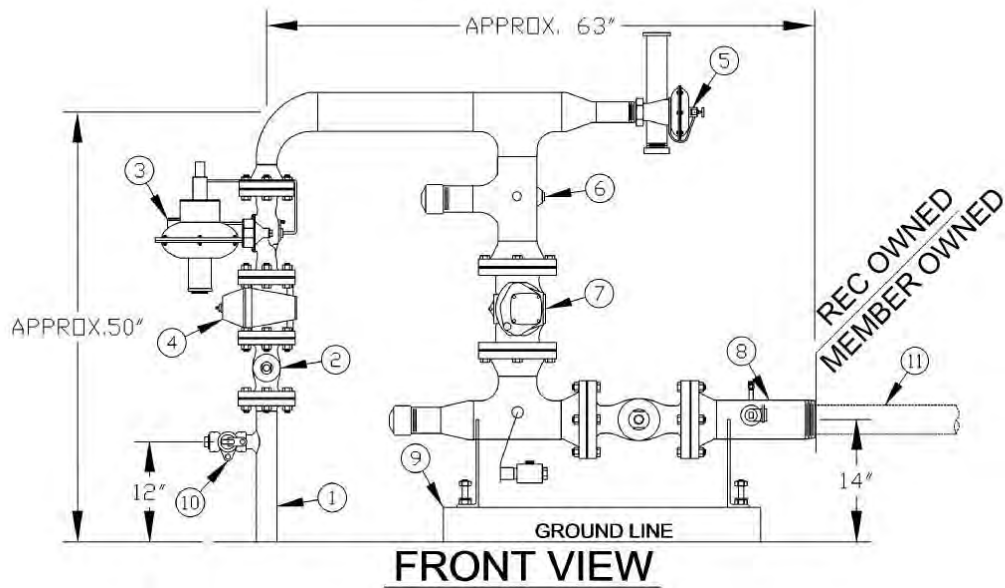
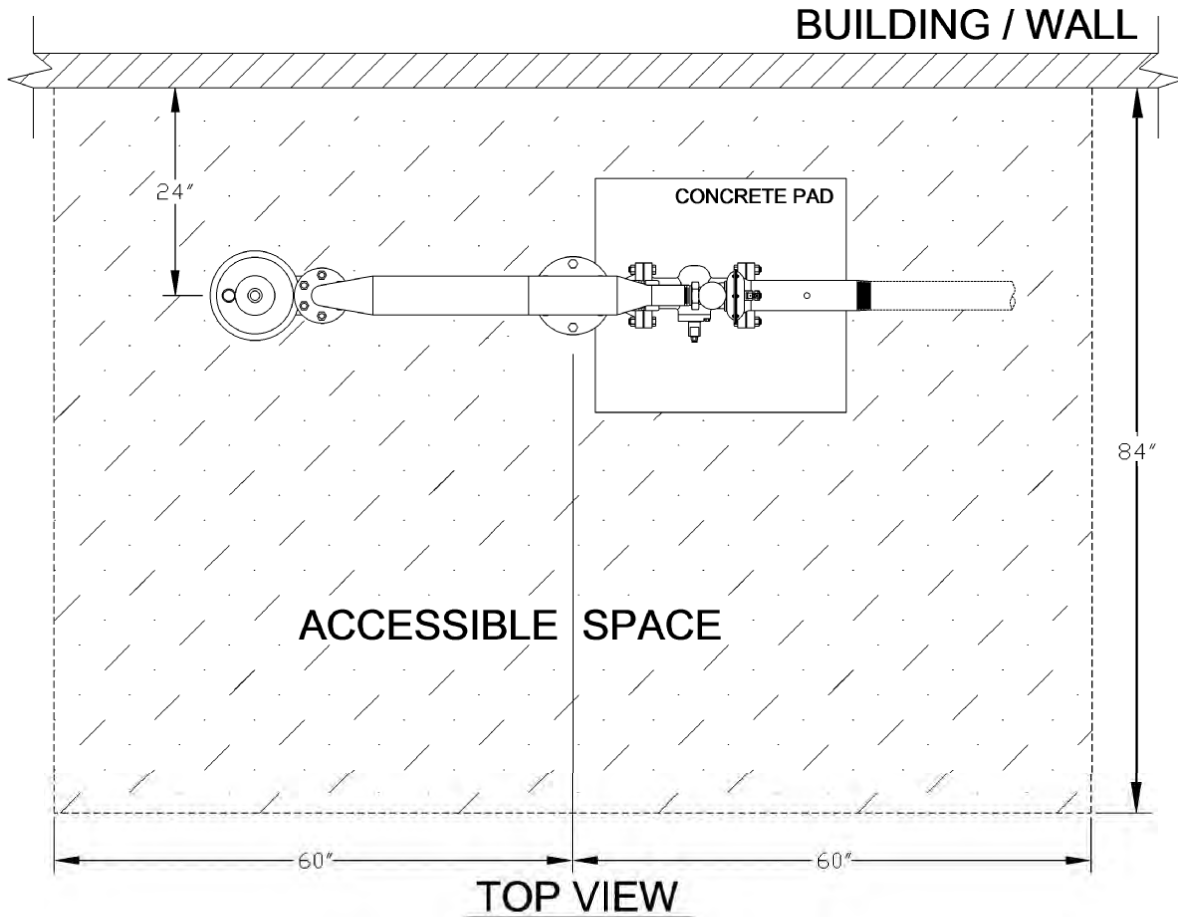

(Dimensions Approximate)



GAS METER CONNECTION

14,601 to 19,000 scfh at 5 psig delivery pressure

REC will install, own, and maintain:

- 1) Gas service lateral.
- 2) Gas service shutoff valve.
- 3) Gas regulator.
- 4) Gas strainer.
- 5) Gas relief valve.
- 6) Gas meter connection.
- 7) Gas meter.
- 8) Concrete meter pad.
- 9) Bypass connection.
- 10) 2" valve.
- 11) 2" steel nipple (on meter connection outlet).

The member shall install, own and maintain:

- 12) All member piping.

(See figure on next page.)

All external member piping must securely supported and located where it will be protected from physical damage (see page 3 of this chapter for piping requirements for copper or CSST).

NOTE: Work with REC for meter connections greater than 19,001.



GAS METER CONNECTION (Continued)

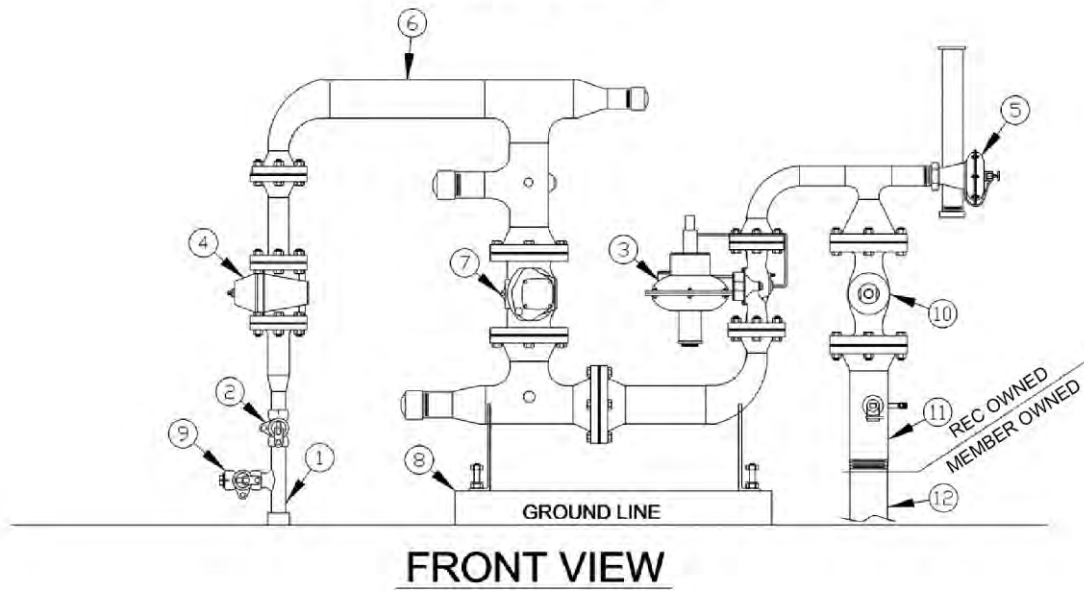
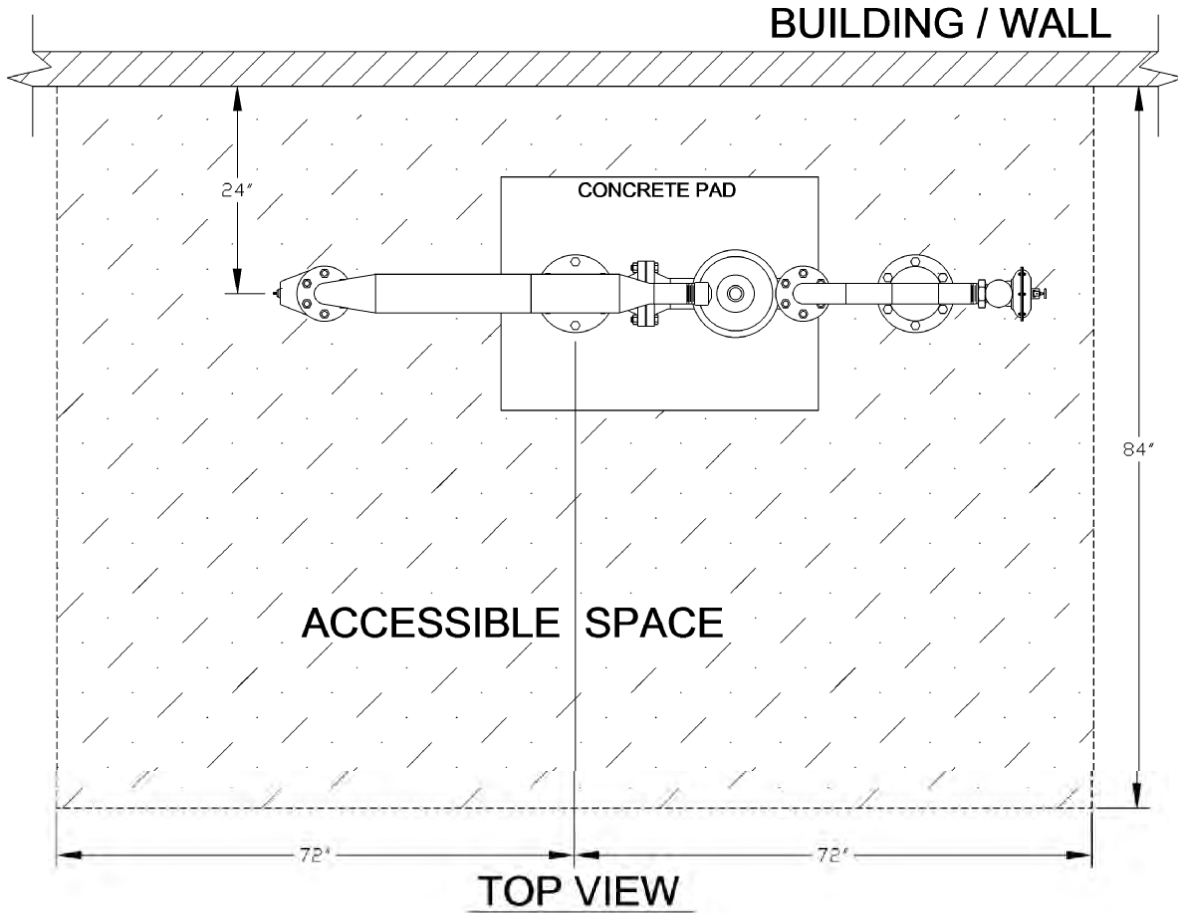

(Dimensions Approximate)



MULTIPLE GAS METER CONNECTION

For two meters:

0 to 250 scfh at 7" wc or 2 psig delivery pressure

REC will install, own and maintain:

- 1) Gas service lateral.
- 2) Gas service shutoff valve.
- 3) Gas regulator.
- 4) Gas meter connection.
- 5) Gas meter.

The member shall own and maintain:

- 6) 1" shutoff valve (provided by the utility).
- 7) All member piping.

(See figure on next page.)

All external members' piping must be securely supported and located where it will be protected from physical damage. See page 2 of this chapter for marking requirements for identifying member piping in a multiple meter installation, as well as for piping

For multiple meter installations other than those described above, consult REC



MULTIPLE GAS METER CONNECTION - Continued

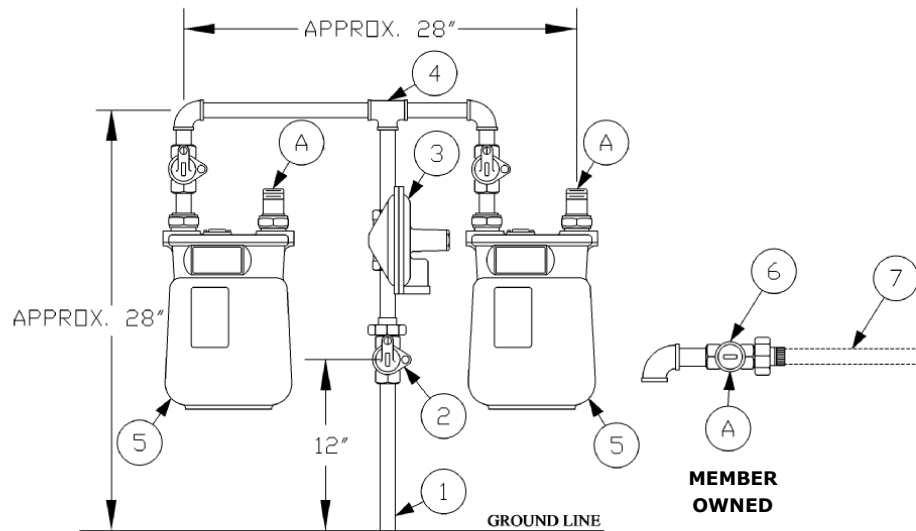
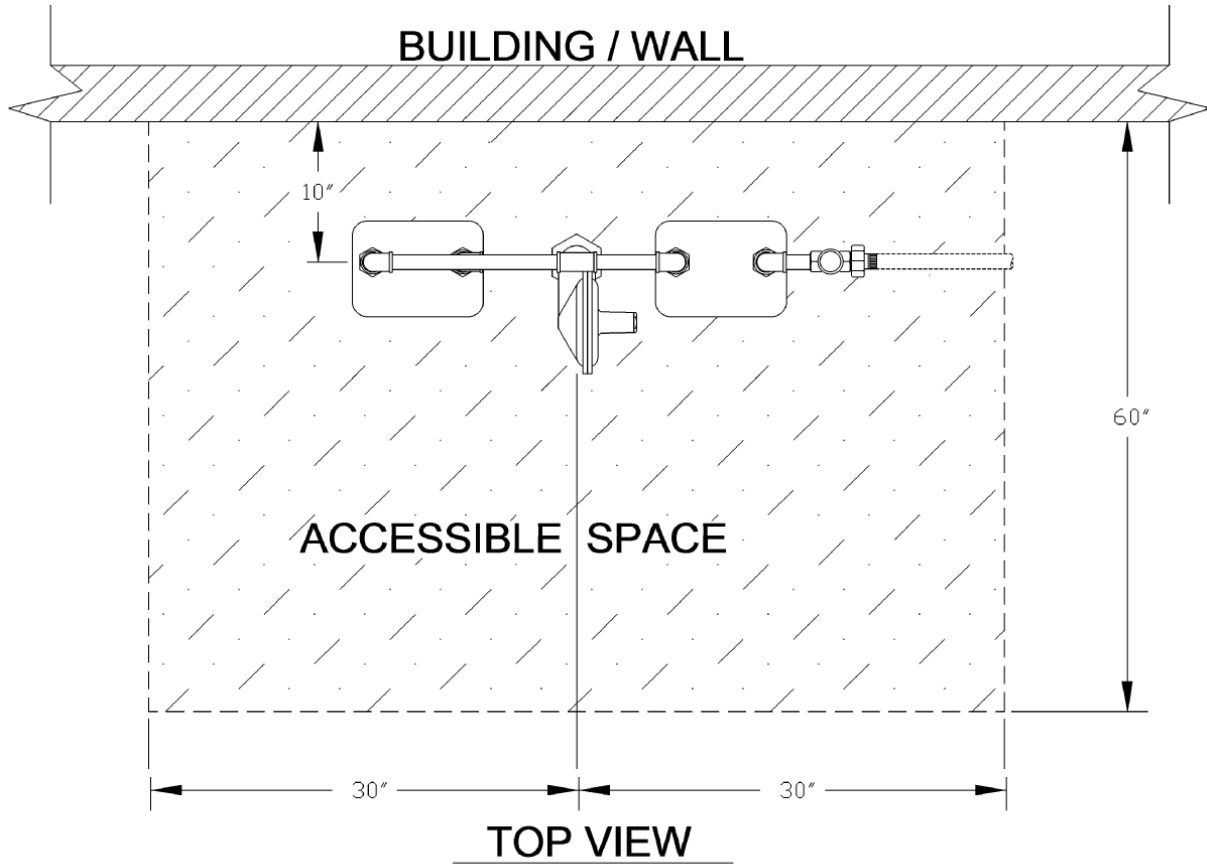

FRONT VIEW

(Dimensions Approximate)



GAS METER SET CLEARANCES

- A. The following clearances are based on code requirements and/or REC standards and shall apply to all new and relocated gas meter set installations. Local codes may require more stringent clearances. Check with your local governing authorities.
- B. REC may refuse or disconnect service to any outside meter set installation that, in the judgment of REC:
- is not located in such a way that escaping gas will flow freely to the atmosphere.
 - is not in a location that would allow REC safe and reliable access to the meter set.
 - is in a location where excessive ice, water, or condensation could build up on the meter set or relief vent.
- C. Below are required and recommended minimum clearances to provide for safe, accessible, and protected placement of a new or relocated meter set installation. All clearance measurements are from the regulator relief vent or, in the case of a commercial/industrial meter set, from the relief valve outlet point, if so equipped. Refer also to the clearance illustrations on the following pages.

Required Clearances for Acceptable Meter Set Placement:

- 1) Minimum 3 feet radial clearance from any source of ignition (NFPA 54, Section 5.8.5).
- 2) Minimum 5 feet horizontal clearance from a pad mounted transformer.
- 3) Minimum 10 feet radial clearance from all powered building air intakes including window or wall-mounted air conditioning units.

Recommended Clearances for Acceptable Meter Set Placement:

- 4) Do not locate meter set and/or regulator directly under air intake or exhaust vents.
- 5) Minimum 3 feet radial clearance from all doors and operable windows.
- 6) Minimum 3 feet radial clearance from communications box.
- 7) Minimum 3 feet radial clearance from electric motors and electrical outlets.
- 8) Minimum 3 feet radial clearance from an electric meter.
- 9) Minimum 3 feet horizontal clearance from all water spigots.
- 10) Minimum 3 feet horizontal clearance from all non-powered combustion air intakes.
- 11) Minimum 3 feet horizontal clearance from all exhaust vent openings.
- 12) Minimum 3 feet horizontal clearance from sealed central air conditioning or heat pump units (including electric box).
- 13) Minimum 6 feet vertical clearance from decks, porches, balconies, and stairs.
- 14) Minimum 6 feet vertical clearance from soffit vent opening.



GAS METER SET CLEARANCES - Continued

RADIAL

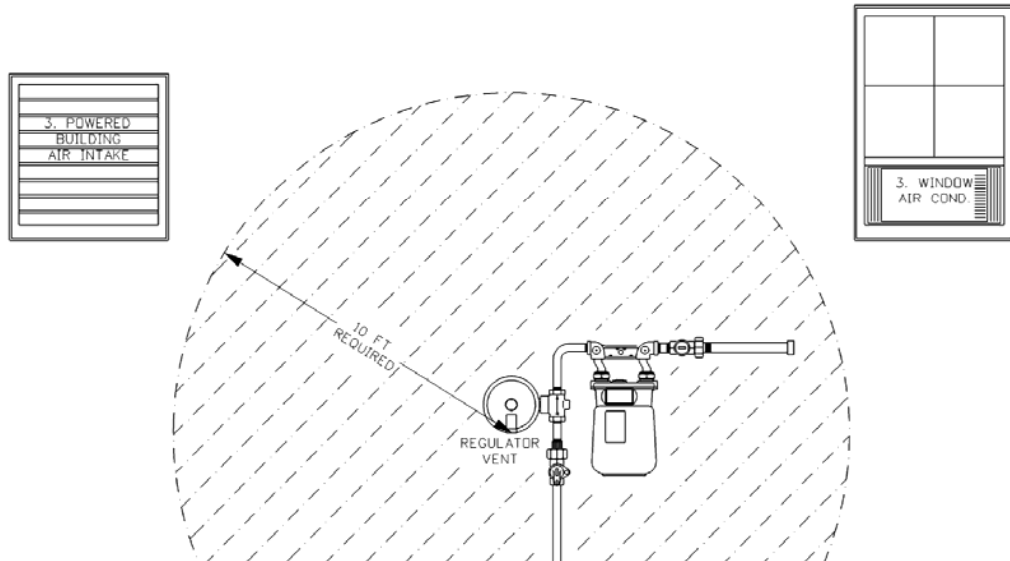

NOTE: All clearances measured from outlet of regulator relief vent.

RADIAL

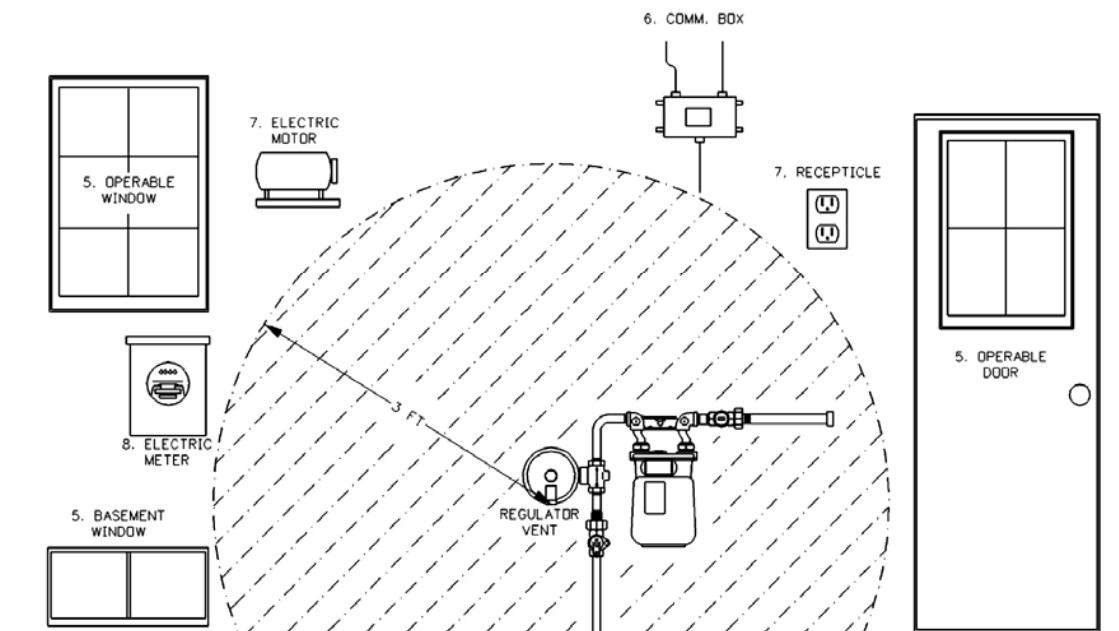

NOTE: All clearances measured from outlet of regulator relief vent.



GAS METER SET CLEARANCES - Continued

HORIZONTAL

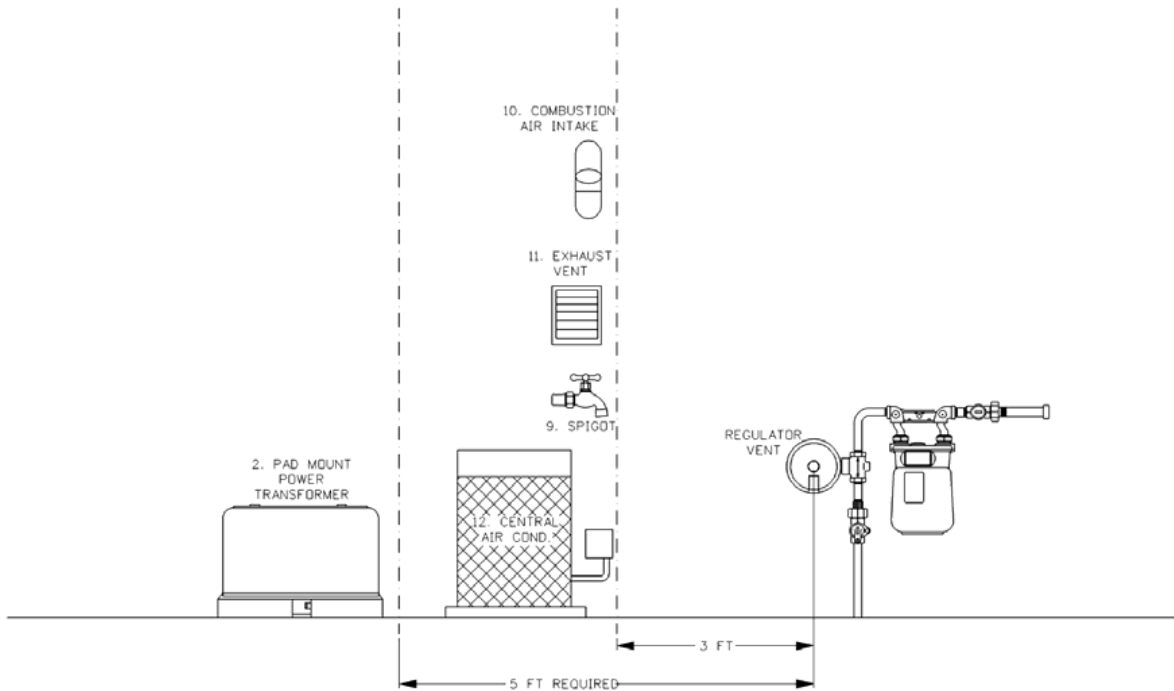

NOTE: All clearances measured from outlet of regulator relief vent.

VERTICAL

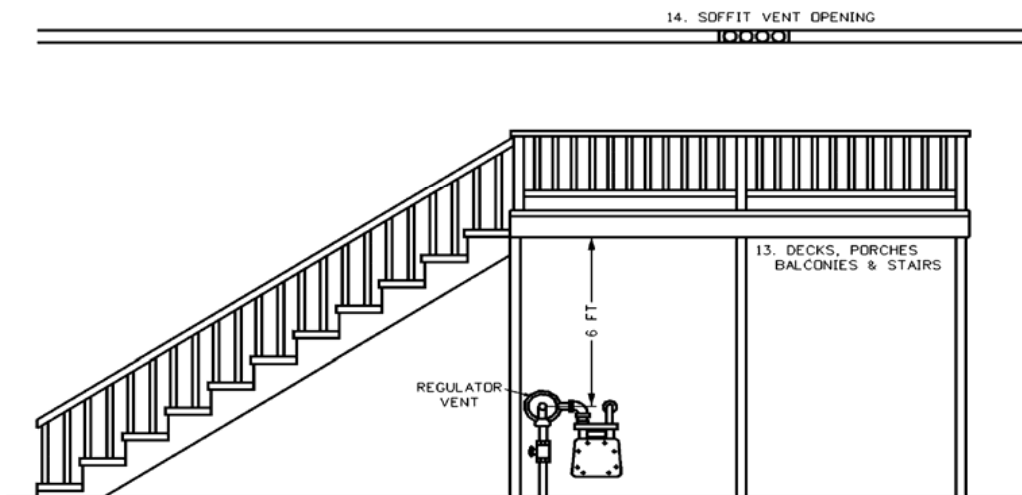

NOTE: All clearances measured from outlet of regulator relief vent.



Rock Energy Cooperative – Gas Service Manual

Chapter 7 – Manufactured Homes

Issued: August 12, 2011

SCOPE

- A. Manufactured and mobile homes were redefined by the U.S. Department of Housing and Urban Development (HUD) in 1982 and shall be referred to as a “manufactured home” throughout this manual. These homes are defined as one that is built on a permanent steel chassis and designed for use as a dwelling with or without a permanent foundation. This includes single-wide homes and double-wide homes (etc.). These are identified with a label on the side and 1 foot from the corner. This label reads as follows: AS EVIDENCED BY THIS LABEL NO. PFS-00000 THE MANUFACTURER CERTIFIES TO THE BEST OF THE MANUFACTURER’S KNOWLEDGE AND BELIEF THAT THIS MANUFACTURED HOME HAS BEEN INSPECTED IN ACCORDANCE WITH THE REQUIREMENTS OF THE DEPARTMENT OF HOUSING AND URBAN DEVELOPMENT AND IS CONSTRUCTED IN CONFORMANCE WITH THE FEDERAL MANUFACTURED HOME CONSTRUCTION AND SAFETY STANDARDS IN EFFECT ON THE DATE OF MANUFACTURE. SEE DATE PLATE.

 - B. A manufactured home supported on an all-weather wood, concrete, or concrete block foundation, constructed in accordance with a recognized building code, and permanently connected water and sewer systems can be considered a permanent dwelling. Service to these manufactured homes may be installed in accordance with Chapter 6, Metering Installations and Member Piping, Page 5.
-

GENERAL

- A. Members shall consult REC before a manufactured home installation is planned or started. The manufactured home meter and service installation shall be located external to the manufactured home and not under, on, or in the manufactured home.

- B. If rebuilding and/or relocation of the gas main, service, or metering equipment is required, the member may be required to pay the entire cost.

- C. Manufactured homes not supported as described in the Scope section above must have a manufactured home flex connector approved for outdoor use between the manufactured home and supply piping (NFPA 54, Section 9.6).



Each flexible supply connector shall be installed completely outside the manufactured home and skirting in such a manner as to provide for immediate visible inspection and flexibility during frost conditions. The flexible connector shall be no more than 6 feet in length with a capacity rating adequate to supply the connected load. (See Gas Service to a Single Manufactured Home in this chapter.) Exterior piping must be supported at intervals no greater than 4 feet.

The manufacturers listed below provide flexible connectors that meet NFPA 54, Section 9.6, and ANSI Z21.75 and are considered acceptable by REC. This list does not include all manufacturers that meet these criteria but is intended to provide a sample of sources from which acceptable connectors can be obtained.

<u>Manufacturer</u>	<u>Trade Name</u>
Dormont	Super-Safe
BassCraft	ProCoat
Tru-Flex	Home-Flex

MANUFACTURED HOME PARKS

- A. The gas distribution system in a manufactured home park will be installed and owned by REC to each metering point. The park owner or member(s) is responsible for piping from the meter installation to the manufactured home(s).
- B. All member-owned metallic fuel gas piping systems shall comply with corrosion control requirements of the applicable federal, state, and local codes and NFPA 54 Chapter 7.
- C. For suggestions regarding member-owned material, contact REC.



GAS SERVICE TO A SINGLE MANUFACTURED HOME

A. For a meter set adjacent to the manufactured home:

REC will install, own, and maintain:

- 1) Gas service lateral.
- 2) Gas service shutoff valve.
- 3) Gas regulator.
- 4) Gas meter connection.
- 5) Gas meter.
- 6) Fence post.
- 7) Fence post clamp.

The member shall own and maintain:

- 8) 1" shutoff valve (provided by the utility).
- 9) All member piping.
- 10) Flexible supply connector.

(See figure on next page.)

All external member piping must be securely supported at no more than 4-foot intervals and located where it will be protected from physical damage. (See Chapter 6, Metering Installations and Member Piping, for piping requirements for copper or CSST.)



GAS SERVICE TO A SINGLE MANUFACTURED HOME (Continued)

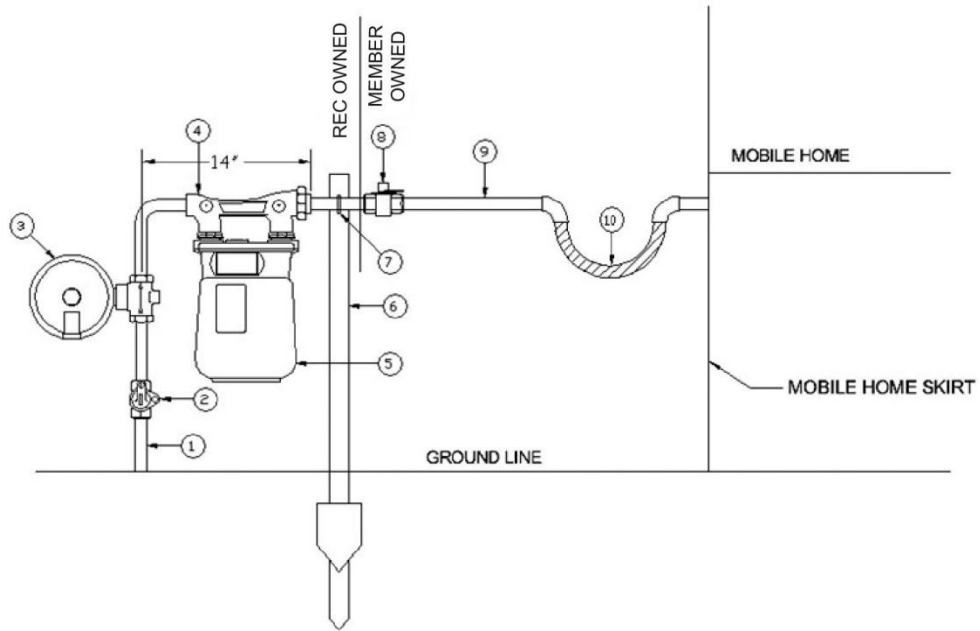



GAS SERVICE TO A SINGLE MANUFACTURED HOME (Continued)

B. For a remote meter set at a manufactured home:

REC will install, own, and maintain:

- 1) Gas service lateral.
- 2) Gas service shutoff valve.
- 3) Gas regulator.
- 4) Gas meter connection.
- 5) Gas meter.
- 6) Fence post.
- 7) Fence post clamp.

The member shall own and maintain:

- 8) 1" shutoff valve (provided by the utility).
- 9) All member piping.
- 10) Flexible supply connector.

All external member piping must be securely supported and located where it will be protected from physical damage. (See Chapter 6, Metering Installations and Member Piping, for piping requirements for copper or CSST.)

Recommended but not required:

- 11) 1" Black malleable iron union.
- 12) 1" Anodeless preformed riser.
- 13) Steel fence post support (to be strapped to riser).
- 14) 1" CTS polyethylene plastic pipe.
- 15) Tracer wire.

(See figure on next page.)



GAS SERVICE TO A SINGLE MANUFACTURED HOME (Continued)

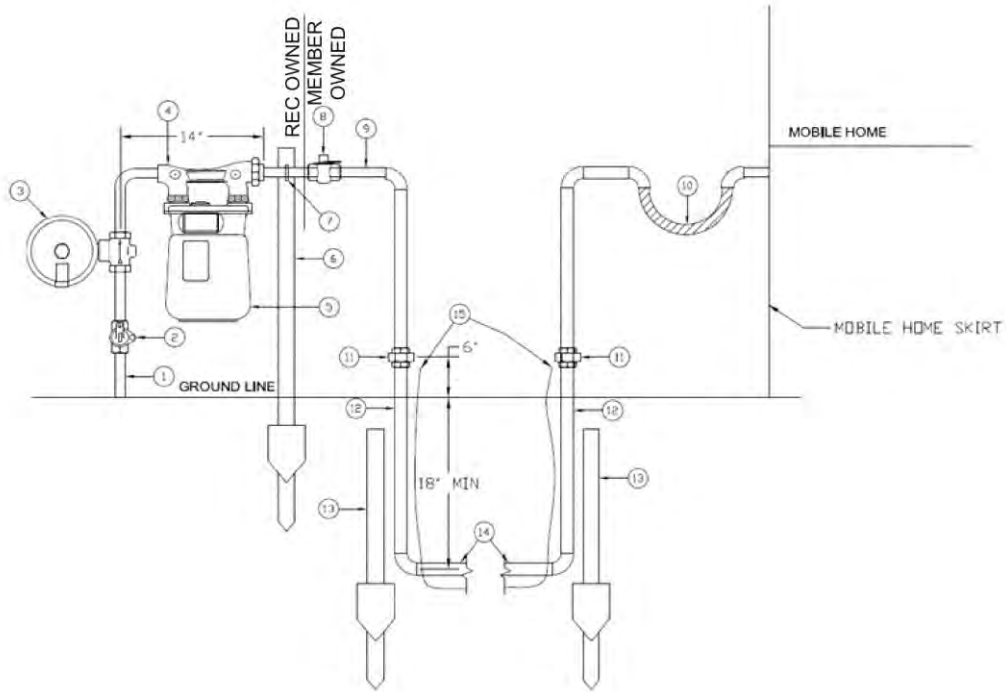



Rock Energy Cooperative – Gas Service Manual

Appendix A

Issued: August 12, 2011

MEMBER PIPING MATERIAL SPECIFICATIONS

The manufacturers listed below provide gas materials that are considered acceptable by REC. This list does not include all manufacturers that meet these criteria but is intended to provide a sample of sources from which acceptable gas materials can be obtained.

Valves

All member-provided valves must be rated at the pressures listed below.

Threaded Valves: ½”, ¾”, 1”, 1-1/4”, 2”:

Valve, gas, plug, non-insulating, threaded, material is cast iron or ductile iron, tamperproof, minimum working pressure 100 psig, rated for natural gas.

Manufacturer

A. Y. McDonald
Rockford Eclipse
Mueller

Flanged Valves: 2”, 3”, 4”:

Valve, gas, plug, flanged, minimum ANSI 125 rated (working pressure 200 psig), wrench operated, material is cast iron, ductile iron or steel, rated for natural gas.

Manufacturer

Nordstrom/Flowsolve
Resun
Walworth

Corrugated Stainless Steel Tubing (CSST) Pipe

Manufacturer

Ward Manufacturing
Omegaflex
Gastite
Parker Hannifin Corporation
Tru-Flex Metal Hose
Metal-Fab Inc.



Underground Risers

Manufacturer

Perfection
Chicago Fittings

Flanges

Type: Threaded
Size: 3", 4"
Material: Forged Steel
Rating: ANSI 150 class preferred, minimum ANSI 125

Flanges must meet requirements of ANSI B16.5 and MSS-SP44.

Note: These minimum flange requirements apply to any member flange that will meet up with a flange on REC side piping. All other flanges on customer piping must meet the requirements of ANSI B16.1, B16.20, or MSS SP-6 per NFPA 54, Section 5.6.10.

Flex Connectors

Approved flexible connectors that meet NFPA 54, Section 9.6, and ANSI Z21.75.

<u>Manufacturer</u>	<u>Trade Name</u>
Dormont	Super-Safe
BrassCraft	ProCoat
Tru-Flex	Home-Flex



CONVERSION CHART

ENERGY CONVERSION FACTORS

1 CF (Cubic Feet) = Approximately 1,000 BTU C = Hundred

1 CCF = 100 CF = 1 Therm M = Thousand

1 Therm = 100,000 BTU = 100 CF = 0.1 MCF MM = Million

10 Therms = 1 MCF = 1 MMBTU DTH = Dekatherm

1 MCF = 1,000 CF = 10 CCF = 10 Therms = 1 DTH

1 Quad = 10⁹ MCF = 10¹⁰ Therms = 10¹⁵ BTU

C= Hundred

M= Thousand

MM = Million

DTH = Dekatherm

Comparative Thermal Values	1.00 million BTU	24.0 million BTU	0.0916 million BTU	0.125 million BTU	0.139 million BTU	0.150 million BTU	0.003412 million BTU
Natural Gas 1,000 BTU/ CU FT	1,000 CU FT	24,000 CU FT	91.600 CU FT	125.000 CU FT	139.000 CU FT	150.000 CU FT	3.412 CU FT
Coal 12,000 BTU/LB	83.333 LB	2,000 LB	7.633 LB	10.417 LB	11.583 LB	12.500 LB	0.2843 LB
Propane 91,600 BTU/GAL	10.917 GAL	262.009 GAL	1 GAL	1.365 GAL	1.517 GAL	1.638 GAL	0.0373 GAL
Gasoline 125,000 BTU/GAL	8.000 GAL	192.000 GAL	0.733 GAL	1 GAL	1.112 GAL	1.200 GAL	0.0273 GAL
Fuel Oil #2 139,000 BTU/GAL	7.194 GAL	172.662 GAL	0.659 GAL	0.899 GAL	1 GAL	1.079 GAL	0.0245 GAL
Fuel Oil #6 150,000 BTU/GAL	6.666 GAL	160.000 GAL	0.611 GAL	0.833 GAL	0.927 GAL	1 GAL	0.0277 GAL
Electricity 3,412 BTU/KWH	293.083 KWH	7,033.998 KWH	26.846 KWH	36.635 KWH	40.739 KWH	43.962 KWH	1 KWH



Request for Residential Electric and Natural Gas Service

Homeowner and Site Information					
Last Name		First Name		Middle Initial	SS #/Fed. ID
New Service Address/Fire Number & Street			City / State / Zip		
Existing Mailing Address/Fire Number & Street			City / State / Zip		
Daytime Phone Number	Evening Phone Number		Email Address		
Check One City Town Village		City/Town/Village Name		Subdivision Name	Lot Number
County	Square Footage of Dwelling		Dwelling Type (Check One) Single Family Multi-Unit		Number of Units
Billing Information					
Who should be billed for electric/gas installation? Builder/Contractor Homeowner			Who should be billed for electric/gas usage during construction? Builder/Contractor Homeowner		
Contractor Information					
Builder/Contractor Name		Contact Person Name		Federal Tax ID Number	
Address/Fire Number # & Street			City / State / Zip		
Daytime Phone Number	Evening Phone Number		Email Address		
Electrical Contractor		Work Phone Number		Cell Phone Number	
Heating Contractor		Work Phone Number		Cell Phone Number	
Electric Service Requirements					
Service Amps: 100 200 300 Other:			Service Type: Overhead Underground		
Distributed Generation: Yes No			Voltage: 120/240 Other:		
List any electric devices that may significantly impact electrical consumption (e.g. instant water heaters, motors, electric vehicles, air compressors):					
Natural Gas Equipment					
Heating	Quantity	BTUs	Water Heater	Quantity	BTUs
Range	Quantity	BTUs	Dryer	Quantity	BTUs
Water Heater Instantaneous	Quantity	BTUs	Other (Generator, Pool, Heater, etc.)	Quantity	BTUs
Approval and Acceptance					
I have read and understand the terms and conditions above and on the Residential Electric & Natural Gas Service Application & Agreement.					
Homeowner/Responsible Party Signature		Homeowner/Responsible Party Printed Name		Date	
Accepted by Rock Energy Cooperative (REC) / For Office Use Only					
Member Account No.	Electric WO No.	Gas WO No.	Map Location		
REC Representative Signature		REC Representative Printed Name		Date	

Residential Electric and Natural Gas
Service Application and Agreement

1. The applicant(s) understand(s) and agree(s) that prior to installation of underground electric lines or natural gas piping, the Homeowner shall have established the final grade of the route and that after installation of the line the grade shall not be increased or decreased more than 6" without the approval of Rock Energy Cooperative (REC). If applicant is not the Homeowner, the applicant is responsible for obtaining such agreement in writing from the Homeowner and providing same to the Cooperative at no expense to the Cooperative.
2. Easement: Right of Access
 - a. The applicant(s), if also the Homeowner(s), grant to the Cooperative the right to clear for installation and maintenance of its overhead and/or underground electric line or gas piping and to use any necessary equipment in, on and across the above described land along highways and along fence lines thereon, and to extend such lines along or near property lines of such premises as may reasonably be necessary to extend service to future applicants for such service, and to permit the attachment of communication lines and equipment owned by others. If applicant is not the Homeowner, the applicant is responsible for obtaining such agreement in writing from the Homeowner and providing same to the Cooperative at no expense to the Cooperative unless same has previously been provided to the Cooperative.
 - b. The applicant(s) jointly with other applicants on the same extension shall, without cost to the Cooperative, maintain a right-of-way, which the Cooperative has the right to clear, adequate for the extension and along a route approved by the Cooperative.
 - c. If requested by the Cooperative, the applicant(s)/homeowner shall grant to the Cooperative an easement in recordable form conveying the rights and privileges in (a) and (b) above. If applicant is not the Homeowner, the applicant is responsible for obtaining the easement in writing from the Homeowner and to provide the same to the Cooperative at no expense to the Cooperative.
3. The applicant(s) individually and jointly agree(s) to indemnify and hold harmless the Cooperative from all claims against the Cooperative because of any injury, disease or death sustained by reason of any act, omission or negligence of the applicant, or any agent, employee or subcontractor thereof.
4. This agreement shall become effective when acceptance of the application has been signed on behalf of the Cooperative.
5. The member is subject to the Cooperative's Deposit Policy.
6. The member is responsible for notifying the Cooperative of contaminated media (soil, groundwater, etc.) that may be present on the premises prior to Cooperative commencing installation or extension of service. The Cooperative reserves the right to consider alternate service routes, if necessary, to avoid contaminated media. The member may be held liable for additional costs incurred by the Cooperative if contaminated media is encountered during the installation of service.

If contaminated media is encountered during the installation or extension of service, the Cooperative shall terminate the installation or extension of service and notify the member. The member is responsible for reporting the discovery of contamination to the appropriate agencies. The member, or landowner, is responsible for management of any contaminated media generated during the installation of service.
7. The Cooperative agrees to furnish, and the member agrees to take and pay for, utility service in accordance with provisions and rates; subject to all applicable rules of the Cooperative, including, but not limited to, terms and conditions on this page hereof; until such time as the member discontinues service or elects to make a written application for service under a different schedule. Such election, however, may not be exercised within a one-year period from the date of this application.
8. Member understands once meters are set, billing will begin.
9. Member understands that upon transfer of demand billed accounts, the member who is responsible for the property at the time of the coincident peak, will be the party responsible for the monthly demand charge.
10. All property of REC, which includes, but is not limited to the meter and transformer, shall remain the property of REC, and shall not be modified or altered in any way. Any modification or alteration could be extremely dangerous and is illegal.

Trench Marking Agreement

The Member agrees the Cooperative will dig, trench, plow or bore on the member's property located at the above address for the installation of utility services. Utility rates are based on rough grade construction meaning the Cooperative will backfill and smooth over any excavations that the Cooperative performs. *Final restoration, grass seeding, watering and mowing are the member's responsibilities.*

Prior to digging, trenching or boring, the Cooperative will identify the route of the proposed excavation. The Cooperative will notify other utility owners to facilitate the marking of existing underground utilities, including electric, telephone and cable TV.

The Member agrees to physically mark the location of any and all owned obstacles that lie underground within ten feet of proposed excavation. Such obstacles include, but are not limited to, septic and sewer systems, buried wires for out-buildings or decorative lighting and LP gas lines. The Member shall mark the location of all of these obstacles with stakes or flags or by painting the ground. The Member hereby accepts any and all responsibility for damage to, or damage done by striking, any such underground obstacle the Member fails to mark or marks incorrectly.

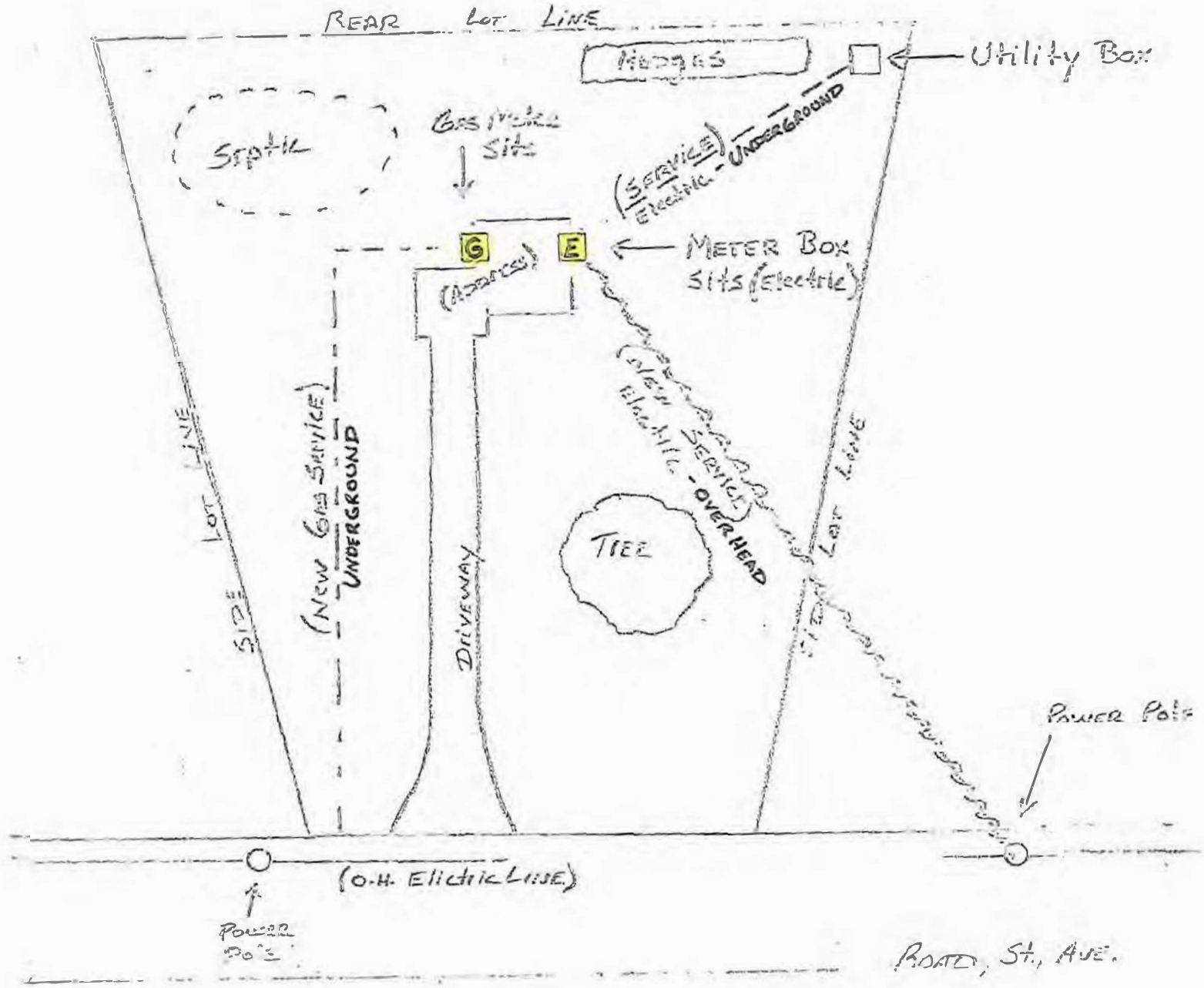

EXAMPLE: Building Site Sketch and Meter Location

Fee Schedule

(Effective: January 1, 2021)

This payment schedule will be reviewed and renewed on an annual basis.

Electric: (minimum charge \$350.00)

- a. Single phase – Primary or Secondary – non-frost rate
Overhead and Underground.....\$13.50 per foot
- b. Single phase – Primary or Secondary – frost rate (Nov. 15 – April 1)
Overhead and Underground.....\$22.50 per foot
- c. Multi Phase – Primary or Secondary – non-frost rate
Overhead and Underground.....\$29.00 per foot
- d. Multi Phase – Primary or Secondary – frost rate (Nov. 15 – April 1)
Overhead and Underground.....\$47.50 per foot
- e. Variance Considerations – The above line extension fees are based on typical conditions; should conditions vary, the cooperative reserves the right to request alternative measures be sought by the requesting party. Additional work by the cooperative as a result in variance shall be billed at the appropriate fee as listed.

Distributed Generation

Generation Capacity	Application Fee ¹	Engineering/Inspection Study Fee ²	Distribution System Study Fee ²
20 kW or less	\$100	Actual Cost, but not less than \$250	No Charge
Greater than 20 kW to 200 kW	\$250	Actual Cost, but not less than \$500	Actual Cost, but not less than \$1,500
Greater than 200 kW to 1 MW	\$500	Actual Cost, but not less than \$2,000	Actual Cost, but not less than \$4,000
Greater than 1 MW	\$1,000	Actual Cost, but not less than \$5,000	Actual Cost, but not less than \$10,000

¹ Subject to Application Fee for each DG submittal, including resubmittals due to incomplete or erroneous applications.

² May include costs from third party consultants.



Rock Energy Cooperative

Natural Gas Disclosure Statement (IL only)

Important Notice: This Disclosure Statement must be signed, dated and returned to Rock Energy Cooperative prior to the natural gas service being turned on at the address below.

Property Owner: _____ Phone Number: _____ - _____ - _____

Address of Gas Meter: _____

The above owner is requesting REC turn on the natural gas service at the above address. The following are the terms and conditions associated with turning the service on. **After the meter is set, the owner is responsible to complete the following prior to sending in the Disclosure Statement:**

- Piping completed from the meter to their appliances
- Pressure test
- External piping painted to protect from corrosion
- Pipe passing through wall wrapped without seams or folds
- Comply to all plumbing codes
- Member underground piping must be preapproved by REC

REC will make one (1) trip, without charge, to turn on the **Meter Stop** at the above natural gas service (this provision does not include nonpayment issues). Any subsequent trips to the above location, beyond the initial service call, will be subject to fees and charges. Should the above natural gas service fail to pass an REC inspection, which will include a gas creep test, REC is required to issue a Caution Card. In addition, REC may require the above owner to furnish a completed and signed Piping Statement and/or approval from the County Plumbing Inspector. The owner is responsible for any and all costs that result beyond the owner's shut-off. The owner is responsible for removing the REC Red Tag, opening the Owners Shut-Off valve and for all reights at the above address (see diagram below).

By signing below, I understand that I am requesting Rock Energy Cooperative turn on the natural gas service at the above address. I understand that Rock Energy Cooperative is not responsible for any and all claims arising from turning on the natural gas service. I agree to the above terms and conditions. I further understand that should I fail to pay any charges to Rock Energy Cooperative, the natural gas service is subject to immediate disconnection. I understand that as the property owner it is my responsibility to notify my tenant, if applicable, of the information provided in this document. I agree that I am responsible for any fees resulting in my failure to do so.

Owner Signature

Date

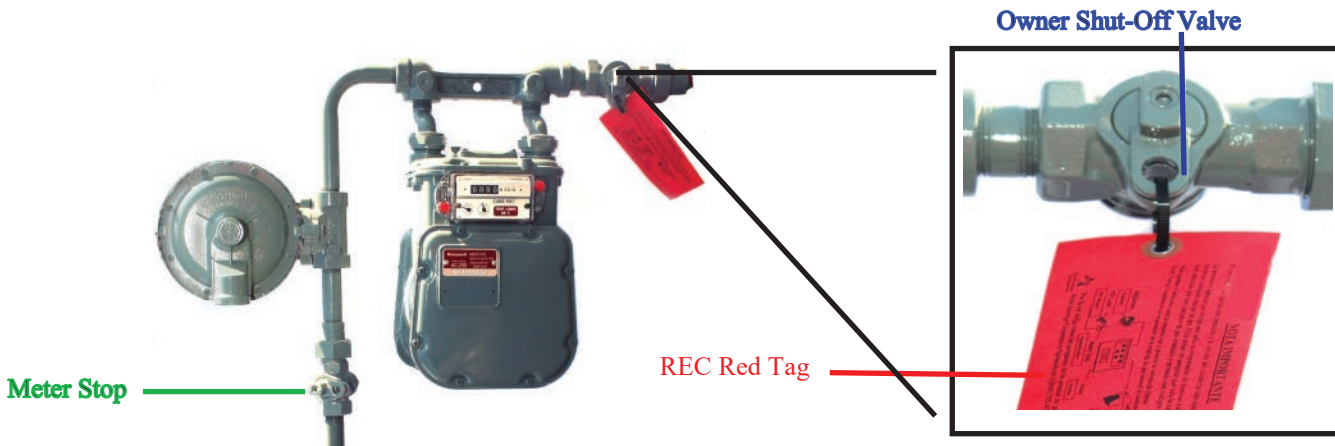

Meter's may vary slightly in appearance, but all have the same equipment in similar locations.